

M. コントロールボックス関係 / Control box mechanism / Schaltkasten
 / Mécanisme du boîtier de contrôle / Mecanismo de la caja de controles

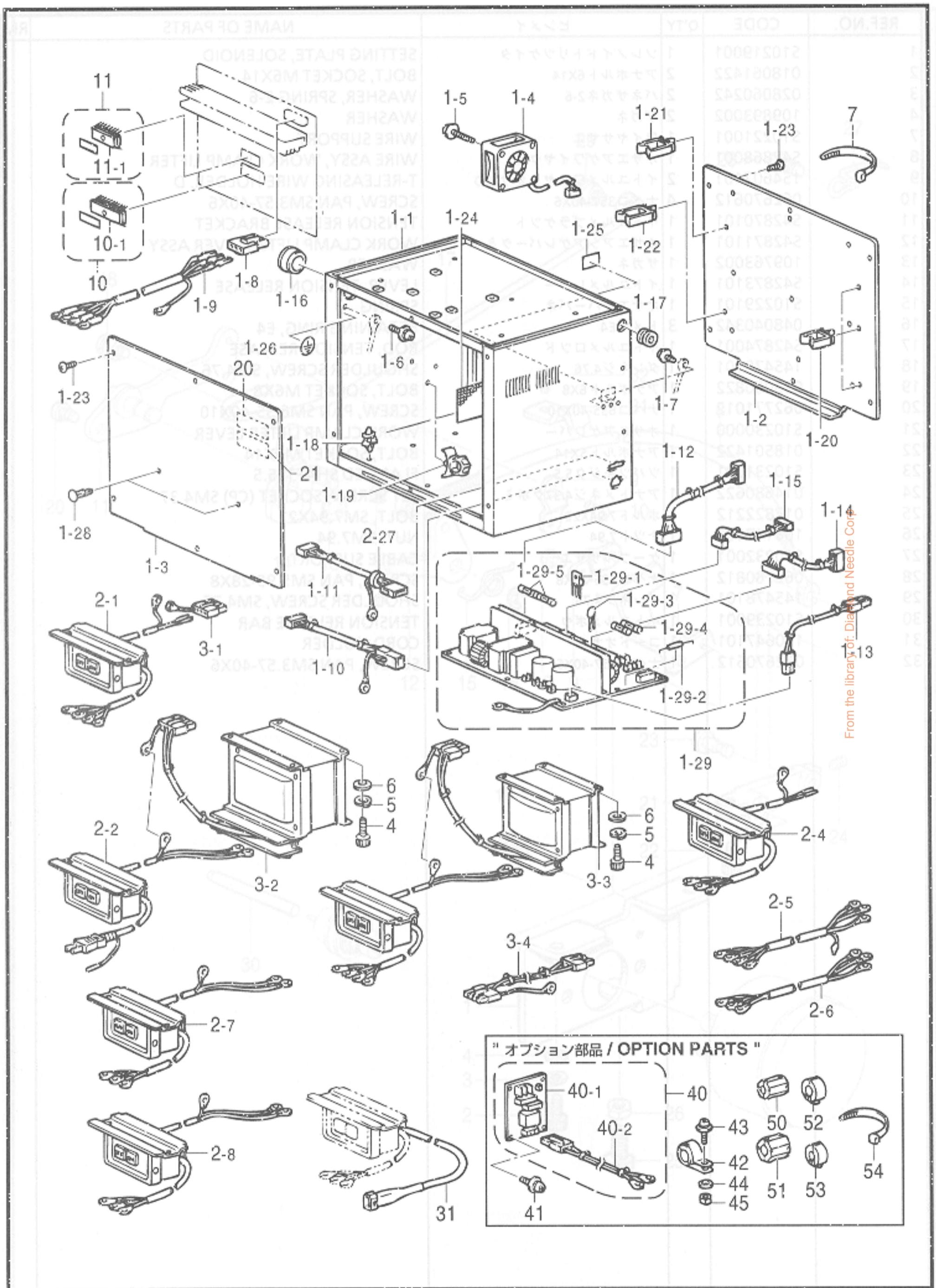

From the library of: Dial and Needle Corp.

M. コントロールボックス関係 / Control box mechanism / Schaltkasten
/ Mécanisme du boîtier de contrôle / Mecanismo de la caja de controles

REF.NO.	CODE	Q'TY	ヒンメイ	NAME OF PARTS	RM
1	S43169009	1	ボックスクミ	BOX ASSY	
1-1	S43170009	1	デンゲンボックス	POWER SUPPLY BOX	
1-2	S43171009	1	キバントリツケイタ	SETTING PLATE, PCB	
1-3	S43172009	1	ボックスフタ	BOX COVER	
1-4	S38094100	2	DCファンモータクミ	DC FAN MOTOR ASSY	
1-5	0A5403006	6	+ナベザクミ4X30DB	SCREW, PAN (S/P WASHER) M4X30	
1-6	0A5400806	1	+ナベザクミ4X8DB	SCREW, PAN (S/P WASHER) M4X8	
1-7	0A5401006	3	ナベコバネヒラ4X10	SCREW, PAN (S/P WASHER) M4X10	
1-8	S16568000	1	コネクタ3191-03R1	CONNECTOR, 3191-03R1	
1-9	S38122200	1	モータケーブルクミ	MOTOR HARNESS ASSY, E	
1-10	S42260000	1	フットSWコード434クミ	FOOT SWITCH HARNESS ASSY, 434	
1-11	S43183100	1	パネルコードBクミ	PANEL HARNESS ASSY, B	
1-12	S38107100	1	セイギヨデンゲンコード	POWER SUPPLY HARNESS, CONTROL	
1-13	S38108000	1	モータデンゲンコード	MOTOR POWER SUPPLY HARNESS	
1-14	S38109100	1	ゲートデンゲンコード	POWER SUPPLY HARNESS, H-P	
1-15	S38110000	1	PERコード	PER HARNESS	
1-16	S43274000	1	ブツシユTB-2938	BUSH, TB-2938	
1-17	S43186000	1	ブツシユBU687B	BUSH, BU687B	
1-18	S00554000	18	サポート6NS	SUPPORT, 6NS	
1-19	S31760000	1	CKSクランプ26L	CORD CLAMP, 26L	
1-20	S43275000	7	コードクランプWS2NS	CORD CLAMP, WS2NS	
1-21	S43276000	3	コードクランプWS3NS	CORD CLAMP, WS3NS	
1-22	S43277000	1	コードクランプWS4NS	CORD CLAMP, WS4NS	
1-23	008400604	12	+トラスコ4X6	SCREW, TRUSS M4X6	
1-24	S43309000	1	ボウジンアミ	FRAGMENT PROTECTOR NET	
1-25	S37059001	1	PEマーク	LABEL, PE	
1-26	S37060001	1	アースマーク	LABEL, GROUNDING	
1-27	S42653000	1	コアTFC-23-11-14	CORE, TFC-23-11-14	
1-28	S34413000	2	スペーサー	SPACER	
1-29	S43173001	1	デンゲンキバンクミ	POWER SUPPLY PCB ASSY	
1-29-1	S38200000	2	MOSFET2SK1938	MOS FET, 2SK1938	
1-29-2	232384001	1	SアブソバDSA362MA	SURGE ABSORBER, DSA362MA	
1-29-3	S38201000	2	バリスタV14D471	VARISTOR, V14D471	
1-29-4	S08030000	2	Gヒューズ5AFB	FUSE, 5A FB	
1-29-5	153242000	2	ヒューズ6A	FUSE, 6A	
2-1	S38112001	1	<三相200V, 220V用> デンゲンSWクミA	< For "3-Phase 200V & 220V" > P-SUPPLY SWITCH ASSY, A 3-P. 200/220V	
2-2	S38114000	1	<100V国内用> デンゲンSWクミB	< For Japan only >	
2-3	S38117000	1	<三相380V用> デンゲンSWクミC	< For "3-Phase 380V" > POWER SUPPLY SWITCH ASSY, C	
2-4	S47592000	1	<単相220V用> デンゲンSWクミD	< For "1-Phase 220V" > P-SUPPLY SWITCH ASSY, D 1-P. 220V	
2-5	S38120000	1	<三相400V用> デンゲンINコードE	< For "3-Phase 400V" > POWER SUPPLY HARNESS, E IN	

From the library of: Diamond Needle Corp

151-V11-502

- ☆ RM欄に※が付いている部品をご注文頂きますと、基板等必要な部品が一式入ったセットになっております。
- ☆ When ordering parts which have an asterisk (※) in the RM column, these parts will be supplied as a set together with other necessary parts such as circuit boards.
- ☆ Bei Bestellung von Teile mit einem Asterrikus (※) aus der Kolonne RM werden diese Teile als Saatz, zusammen mit anderen notwendigen tilen, wie Schaltplatimen geliefert.
- ☆ Si l'on commande des pièces désignées par un astérisque (※) dans la colonne RM, ces pièces seront fournies en jeu avec les autres pièces nécessaires telles que des plaquettes.
- ☆ Al ordenar partes que tienen un asterisco (※) en la columna RM, estas partes serán suministradas como un juego junto con otras partes necesarias como los tableros de circuitos.

M. コントロールボックス関係 / Control box mechanism / Schaltkasten
/ Mécanisme du boîtier de contrôle / Mecanismo de la caja de controles

REF.NO.	CODE	Q'TY	ヒンメイ	NAME OF PARTS	RM
2-6	S43188000	1	<単相230V用> デンゲンINコードF	<For "1-Phase 230V"> POWER SUPPLY IN HARNESS, F	
2-7	S47594000	1	<単相110V, 240V用> デンゲンSWクミG	<For "1-Phase 110V & 240V"> P-SUPPLY SWITCH ASSY, G 1-P. 110/240V	
3-1	S38123000	1	<200V, 220V用> ACINコネクタクミ	<For "200V & 220V"> AC IN CONNECTOR ASSY	
3-2	S43369000	1	<100V, 110V用> ハンカントランスBクミ	<For "100V & 110V"> CONVERSION TRANSFORMER ASSY, B	
3-3	S43370000	1	<240V, 380V, 400V用> ハンカントランスCクミ	<For "240V, 380V & 400V"> CONVERSION TRANSFORMER ASSY, C	
3-4	S43201000	1	<単相230V用> ACINコードF	<For "1-Phase 230V"> AC IN HARNESS, F	
4	018061036	4	アナボルト6X10	BOLT, SOCKET M6X10	
5	028060246	4	バネザガネ2-6	WASHER, SPRING 2-6	
6	025060236	4	ヒラザガネチユウ6	WASHER, PLAIN M 6	
7	228475000	4	ケツソクバンド1.9X80	FASTENING BAND, 1.9X80	
10	S43190000	1	PROMセイギヨクミ	PROM ASSY, CONTROL	
11	S43191000	1	PROMモータクミ	PROM ASSY, MOTOR	
20	S38352101	2	-----	LABEL, ELEC. SHOCK 4 LANG.	
21	S38353101	2	デンゲキラベル.ワ	-----	
31	S43278000	1	< BAS-311E コンプレッサーユニット用 > コンプレッサーハーネス	<For Compressor unit of BAS-311E> COMPRESSOR HARNESS	
40	S40635001	1	" オプション部品 "	" OPTION PARTS "	
40-1	S40616001	1	ノイズフィルタ430Eクミ	NOISE FILTER ASSY, 430E	
40-2	S40624000	1	ノイズフィルタEMCクミ	NOISE FILTER ASSY, EMC	
41	0A4400605	4	ノイズフィルタハーネスA	NOISE FILTER HARNESS, A	
42	S40623000	1	+ナベザクミ4X6DA	SCREW, PAN (S/P WASHER) M4X6	
43	0A5401605	1	EMIコアTR-40-27	EMI CORE, TR-40-27	
44	025040236	1	+ナベザクミ4X16DB	SCREW, PAN (S/P WASHER) M4X16	
45	021400106	1	ヒラザガネチユウ4	WASHER, PLAIN M 4	
50	S40621000	1	ナット1シユ4	NUT, 1 M4	
51	S40622000	1	EMIコアESD-SR-15	EMI CORE, ESD-SR-15	
52	S40764000	7	EMIコアESD-SR-25	EMI CORE, ESD-SR-25	
53	S42653000	3	コアTFC25-15-12	CORE, TFC25-15-12	
54	149809000	6	コアTFC-23-11-14	CORE, TFC-23-11-14	
			タイラツPL	BEAD BAND, L = 200	

From the library of: Diamond Needle Corp

151-V11-502

- ☆ RM欄に※が付いている部品をご注文頂きますと、基板等必要な部品が一式入ったセットになっております。
- ☆ When ordering parts which have an asterisk (※) in the RM column, these parts will be supplied as a set together with other necessary parts such as circuit boards.
- ☆ Bei Bestellung von Teile mit einem Asterrikus (※) aus der Kolonne RM werden diese Teile als Saatz, zusammen mit anderen notwendigen tilen, wie Schaltplatimen geliefert.
- ☆ Si l'on commande des pièces désignées par un astérisque (※) dans la colonne RM, ces pièces seront fournies en jeu avec les autres pièces nécessaires telles que des plaquettes.
- ☆ Al ordenar partes que tienen un asterisco (※) en la columna RM, estas partes serán suministradas como un juego junto con otras partes necesarias como los tableros de circuitos.

M. コントロールボックス関係 / Control box mechanism / Schaltkasten
 / Mécanisme du boîtier de contrôle / Mecanismo de la caja de controles

REF.NO.	CODE	Q'TY	ヒンメイ	NAME OF PARTS	RM
			“ 補給用部品 ”	“ For Supply parts ”	
H-1	S43241009	1	<三相220V, 220V用> ボックスソウクミA1	<For "3-hase 200V & 220V"> POWER SUPPLY BOX ASSY, A1	
H-2	S43242009	1	<単相100V国内用> ボックスソウクミB1	<For Japan only>	
H-4	S43245009	1	<単相220~230V用> ボックスソウクミA2	<For "1-Phase 220V~230V"> POWER SUPPLY BOX ASSY, A2	
H-5	S43246009	1	<三相400V用> ボックスソウクミE	<For 3-hase 400V> POWER SUPPLY BOX ASSY, E	
H-6	S43244009	1	<三相380V用> ボックスソウクミC2	<For 3-Phase 380V> POWER SUPPLY BOX ASSY, C2	
H-7	S43247009	1	<単相230V用> ボックスソウクミF	<For 1-Phase 230V> POWER SUPPLY BOX ASSY, F	
H-8	S43248009	1	<単相110V用> ボックスソウクミB2	<For 1-Phase 110V> POWER SUPPLY BOX ASSY, B2	
H-9	S43240009	1	<単相240V用> ボックスソウクミC3	<For 1-Phase 240V> POWER SUPPLY BOX ASSY, C3	

From the library of: Diamond Needle Corp

151-V11-502

- ☆ RM欄に※が付いている部品をご注文頂きますと、基板等必要な部品が一式入ったセットになっております。
- ☆ When ordering parts which have an asterisk (*) in the RM column, these parts will be supplied as a set together with other necessary parts such as circuit boards.
- ☆ Bei Bestellung von Teile mit einem Asterrikus (*) aus der Kolonne RM werden diese Teile als Saatz, zusammen mit anderen notwendigen tilen, wie Schaltplatimen geliefert.
- ☆ Si l'on commande des pièces désignées par un astérisque (*) dans la colonne RM, ces pièces seront fournies en jeu avec les autres pièces nécessaires telles que des plaquettes.
- ☆ Al ordenar partes que tienen un asterisco (*) en la columna RM, estas partes serán suministradas como un juego junto con otras partes necesarias como los tableros de circuitos.

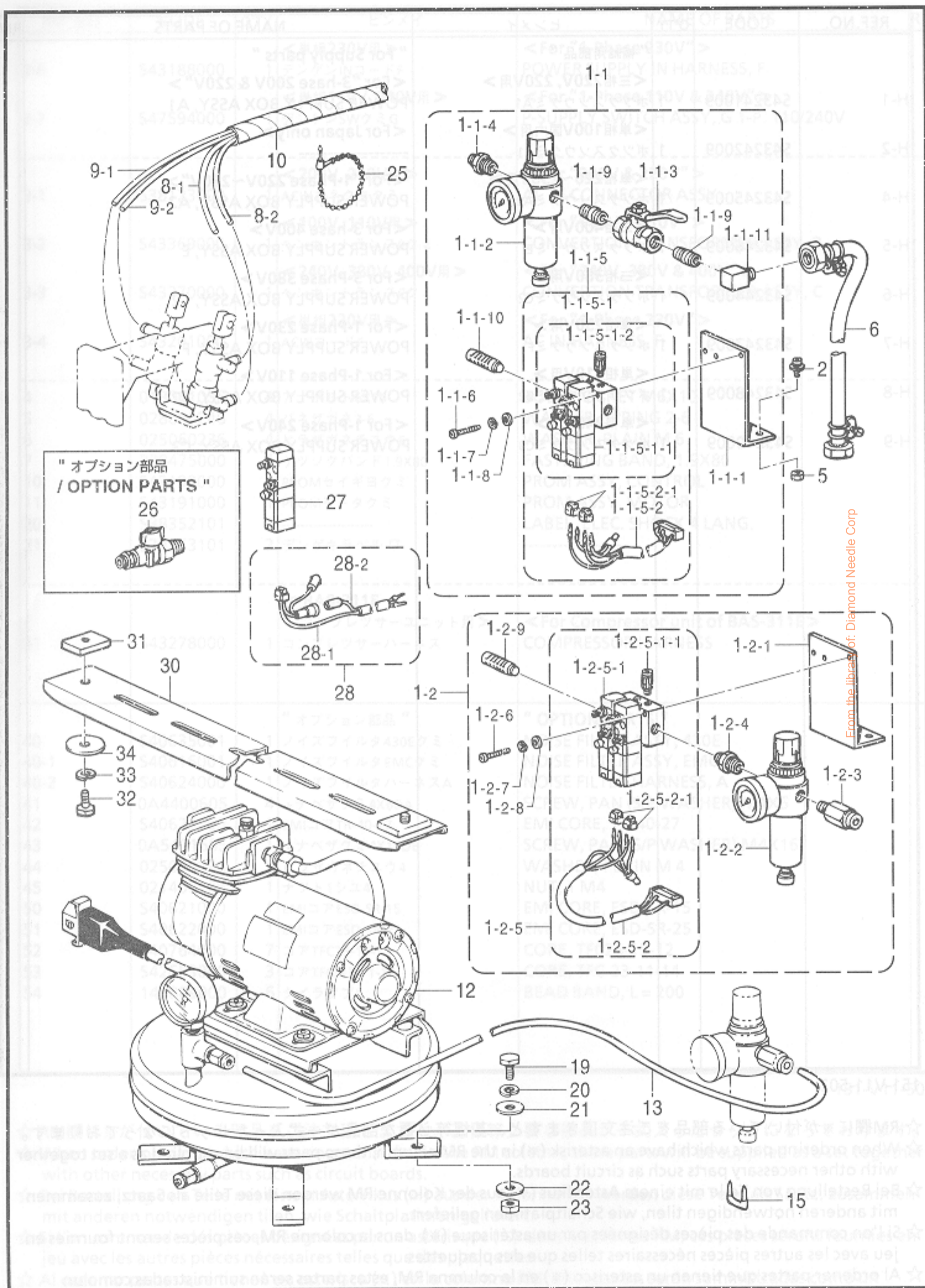

From the library of: Diamond Needle Corp

N. 空圧関係 / Air pressure mechanism / Luftdruck / Mécanisme de la pression d'air / Mecanismo de la presión de aire

REF.NO.	CODE	Q'TY	ヒンメイ	NAME OF PARTS	RM
			<BAS-311E, 311EL用> <コンプレッサー無シ仕様用>	<For "BAS-311E & 311EL"> <For with-out compressor>	
1-1	S43678009	1	デンジバルブ2Aクミ	SOLENOID VALVE ASSY, 2A	
1-1-1	S31551009	1	バルブトリツケイタ2-3	VALVE SETTING PLATE, 2-3	
1-1-2	S09318101	1	インテグレータ	INTEGRATER	
1-1-3	S40628000	1	ボールバルブ1/4	BALL VALVE, 1/4	
1-1-4	S09228000	1	イケイニツブル	NIPPLE	
1-1-5	S43679001	1	デンジバルブ2クミ	SOLENOID VALVE ASSY, 2	
1-1-5-1	S43680001	1	エアマニホルドクミ	AIR MANIFOLD ASSY	
1-1-5-1-1	S43684001	1	エアマニホルド	AIR MANIFOLD	
1-1-5-1-2	S43683001	2	デンジバルブ	SOLENOID VALVE	
1-1-5-1-3	S18415101	4	ハーフユニオンQ4M5	HALF UNION, Q4M5	
1-1-5-2	S43682000	1	バルブハーネスX2クミ	VALVE HARNESS ASSY, X2	
1-1-5-2-1	S12404000	2	クロダバルブコネクタ	VALVE CONNECTOR	
1-1-6	062302506	2	ナベコ3X25	SCREW, PAN M3X25	
1-1-7	028030242	2	バネザガネ2-3	WASHER, SPRING 2-3	
1-1-8	025030232	2	ヒラザガネチユウ3	WASHER, PLAIN M 3	
1-1-9	S40629000	2	バレルニツブル	BARREL NIPPLE	
1-1-10	S23880000	2	エアーマフラー	AIR MUFFLER	
1-1-11	S43686000	1	PTエルボ1/4	ELBOW, PT 1/4	
			<共通部品>	<Common parts>	
2	052501205	2	ナベコバネヒラ5X12	SCREW, PAN (S/P WASHER) M5X12	
5	021500103	2	ナット1シユ5	NUT, 1 M5	
6	149796001	1	ゴムホースカナグツキ	AIR TUBE, W/CONNECTOR	
8-1	S43687001	1	ナイロンチューブR	AIR TUBE, N4-1A L= 1450	
8-2	S43687002	1	ナイロンチューブR	AIR TUBE, N4-1B L= 1450	
9-1	S43688001	1	ナイロンチューブL	AIR TUBE, N4-2A L= 1350	
9-2	S43688002	1	ナイロンチューブL	AIR TUBE, N4-2B L= 1350	
10	S12212000	1	スパイラル290S	SPIRAL, 290S	
26	S25100000	1	ボールバルブクミ	BALL VALVE ASSY	
			<BAS-311E コンプレッサー付仕様用>	<For with compressor of BAS-311E>	
1-2	S43694009	1	デンジバルブ2Bクミ	SOLENOID VALVE ASSY, 2B	
1-2-1	S31551009	1	バルブトリツケイタ2-3	VALVE SETTING PLATE, 2-3	
1-2-2	S09318101	1	インテグレータ	INTEGRATER	
1-2-3	S29710000	1	コネクタ6-1/4	CONNECTOR, 6-1/4	
1-2-4	S09228000	1	イケイニツブル	NIPPLE	
1-2-5	S43679001	1	デンジバルブ2クミ	SOLENOID VALVE ASSY, 2	
1-2-5-1	S43680001	1	エアマニホルドクミ	AIR MANIFOLD ASSY	
1-2-5-1-1	S43684001	1	エアマニホルド	AIR MANIFOLD	
1-2-5-1-2	S43683001	2	デンジバルブ	SOLENOID VALVE	
1-2-5-1-3	S18415101	4	ハーフユニオンQ4M5	HALF UNION, Q4M5	
1-2-5-2	S43682000	1	バルブハーネスX2クミ	VALVE HARNESS ASSY, X2	
1-2-5-2-1	S12404000	2	クロダバルブコネクタ	VALVE CONNECTOR	
1-2-6	062302506	2	ナベコ3X25	SCREW, PAN M3X25	
1-2-7	028030242	2	バネザガネ2-3	WASHER, SPRING 2-3	
1-2-8	025030232	2	ヒラザガネチユウ3	WASHER, PLAIN M 3	
1-2-9	S23880000	2	エアーマフラー	AIR MUFFLER	
			<100V用>	<For 100V>	
12	S05670002	1	コンプレッッサユニット	COMPRESSOR UNIT, 100V	
			<200V用>	<For 200V>	
12	S09393002	1	コンプレッッサユニット	COMPRESSOR UNIT, 200V	

From the library of: Diamond Needle Corp

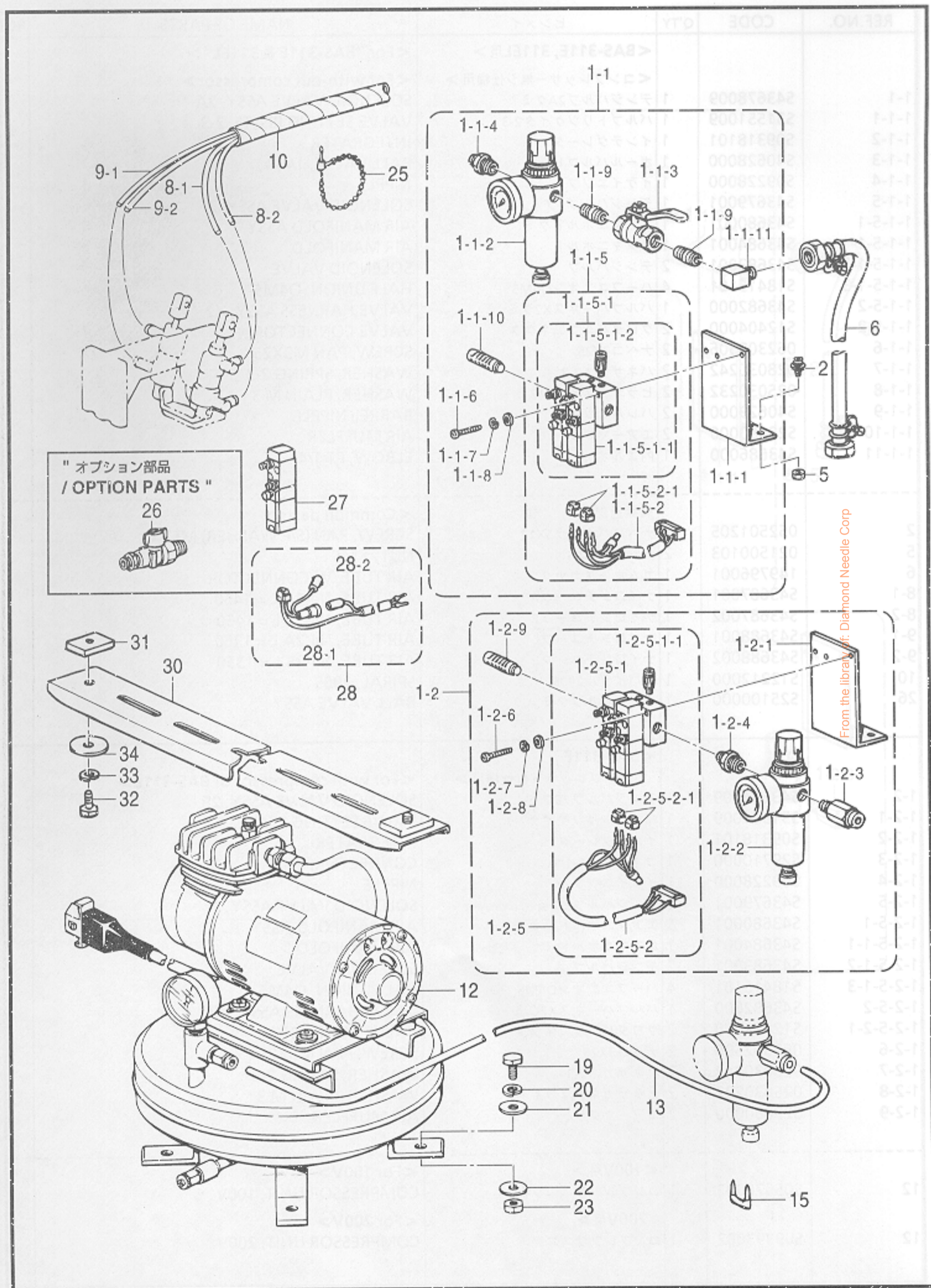

From the library of: Diamond Needle Corp

N. 空圧関係 / Air pressure mechanism / Luftdruck / Mécanisme de la pression d'air
/ Mecanismo de la presión de aire

REF.NO.	CODE	Q'TY	ヒンメイ	NAME OF PARTS	RM
			<BAS-311E コンプレッサ付仕様用>	<For with compressor of BAS-311E>	
13	S32129000	1	エアチューブ	AIR TUBE, 6 L = 1350	
15	200190001	3	ステッブル	STAPLE	
19	017082203	4	ボルト6X22	BOLT, M8X22	
20	028080242	4	バネザガネ2-8	WASHER, SPRING 2-8	
21	025080232	4	ヒラザガネチユウ8	WASHER, PLAIN M 8	
22	025080336	4	ヒラザガネダイ8	WASHER, PLAIN L 8	
23	021080106	4	ナツト1シユ8	NUT, 1 M8	
25	340400001	1	ユニタイバンド	BEAD BAND	
30	S09224002	1	フミイタササエダイ	TREADLE SUPPORT BASE	
31	S09225001	2	4カクナツト	NUT	
32	017081606	2	ボルト8X16	BOLT, M8X16	
33	028080246	2	バネザガネ2-8	WASHER, SPRING 2-8	
34	S09226001	2	フミイタササエザガネ	WASHER	
35	228475000	2	ケツソクバンド1.9X80	FASTENING BAND, 1.9X80	
26	S25100000	1	" オプション部品 " <BAS-311E, 311EL用> ボールバルブウミ	" OPTION PARTS " <For BAS-311E & 311EL> BALL VALVE ASSY	
27	S43683001	1	" 補給用部品 " デンジバルブ	" For Supply parts " SOLENOID VALVE	
28	S43696000	1	バルブハーネスX1	VALVE HARNESS, X1	
28-1	S44746000	1	ツイカバルブハーネス	VALVE HARNESS	
28-2	S44750000	1	ツイカバルブハーネス24V	VALVE HARNESS, 24V	
			GROUND WIRE, 1	GROUND WIRE, 1	
			SCREW, PAN (S/P WASHER) M4X8	SCREW, PAN (S/P WASHER) M4X8	
			SCREW, PAN M3X6	SCREW, PAN M3X6	
			SCREW, PAN M3X6	SCREW, PAN M3X6	
			NUT, 2 M6	NUT, 2 M6	
			WASHER, SPRING 2-6	WASHER, SPRING 2-6	
			CONNECTOR, 3191-09P	CONNECTOR, 3191-09P	
			BEAD BAND, L = 200	BEAD BAND, L = 200	
			BEAD BAND	BEAD BAND	
			EM-SWITCH ASSY	EM-SWITCH ASSY	
			CORD HOLDER	CORD HOLDER	
			SCREW, PAN (S/P WASHER) M4X8	SCREW, PAN (S/P WASHER) M4X8	
			FASTENING BAND, 1.9X80	FASTENING BAND, 1.9X80	
			BEAD BAND	BEAD BAND	
			CORD HOLDER, 6N	CORD HOLDER, 6N	
			BEAD BAND, L = 200	BEAD BAND, L = 200	
			<For solenoid type of BAS-311E>	<For solenoid type of BAS-311E>	
			CLAMP SOCKET PARTS	CLAMP SOCKET PARTS	
			SCREW, FLAT M5X10	SCREW, FLAT M5X10	
			CORD HOLDER, 6N	CORD HOLDER, 6N	
			<311EL用 / For 311EL>	<311EL用 / For 311EL>	
			<311E用 X-1用>	<For setting the Motor X-1 of BAS-311EL>	
			ボルト, SOCKET M4X12	BOLT, SOCKET M4X12	
			ワッシャー, PLAIN M8	WASHER, PLAIN M8	
			ワッシャー, SPRING 2-4	WASHER, SPRING 2-4	
			" オプション部品 "	" OPTION PARTS "	
5-2	S43204000	1	EMロックスイッチウミ	EM LOCK-SWITCH ASSY	
	S37057001	1	EMスイッチスペーサ	EM-SWITCH SPACER, 3	

From the library of: Diamond Needle Corp

P. 電装品関係 / Power supply equipment mechanism / Stromversorgung
 / Mécanisme de l'équipement en alimentation électrique
 / Mecanismo del equipo de alimentación de corriente

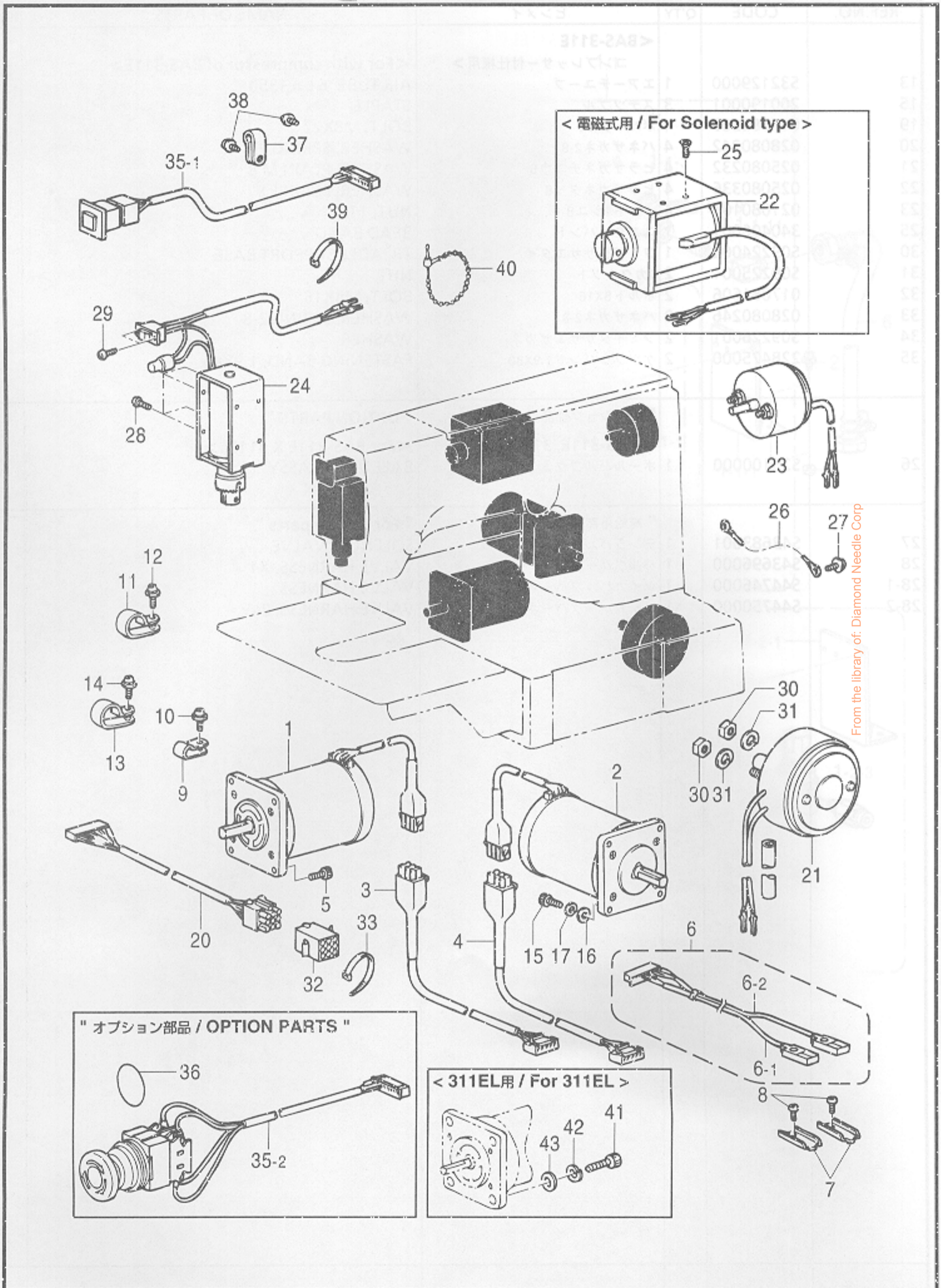

From the library of: Diamond Needle Corp

P. 電装品関係 / Power supply equipment mechanism / Stromversorgung
 / Mécanisme de l'équipement en alimentation électrique
 / Mecanismo del equipo de alimentación de corriente

NAME OF PARTS

REF.NO.	CODE	Q'TY	ヒンメイ	NAME OF PARTS	RM
1	S43192000	1	パルスモータXクミ	PULSE MOTOR ASSY, X	
2	S43194000	1	パルスモータYクミ	PULSE MOTOR ASSY, Y	
3	S43196000	1	パルスモータXハーネス	PULSE MOTOR HARNESS, X	
4	S43197000	1	パルスモータYハーネス	PULSE MOTOR HARNESS, Y	
5	018400822	4	<BAS-311E用> アナボルト4X8	<For BAS-311E> BOLT, SOCKET M4X8	
6	S44663000	1	ゲンテンセンサハーネスクミ	SENSOR HARNESS ASSY, H/P	
6-1	S44665000	1	キンセツセンサGL-12F	PROXIMITY SENSOR, GL-12F	
6-2	S44665002	1	キンセツセンサGL-12F	PROXIMITY SENSOR, GL-12F	
7	S46476001	2	センサカナダ	SENSOR BRACKET	
8	002301203	2	+ナベコ3X12	SCREW, PAN M3X12	
9	S10243000	3	ナイロンクランプNK-3N	CORD HOLDER, NK-3N	
10	0A5400806	3	+ナベザクミ4X8DB	SCREW, PAN (S/P WASHER) M4X8	
11	S25664000	1	コードホルダ#6	CORD HOLDER, 6N	
12	0A5400806	1	+ナベザクミ4X8DB	SCREW, PAN (S/P WASHER) M4X8	
13	149287000	3	ナイロンクランプ	CORD HOLDER, 7N	
14	0A5400806	3	+ナベザクミ4X8DB	SCREW, PAN (S/P WASHER) M4X8	
15	018401222	4	アナボルト4X12	BOLT, SOCKET M4X12	
16	025040232	4	ヒラザガネチユウ4	WASHER, PLAIN M 4	
17	028040242	4	バネザガネ2.4	WASHER, SPRING 2-4	
20	S43206000	1	ソレノイドハーネスクミ	SOLENOID HARNESS ASSY	
21	S43202000	1	カンケツソレノイドクミ	STEPPING SOLENOID ASSY	
21-1	S10244000	1	カンケツソレノイド	STEPPING SOLENOID	
23	S07818009	1	イトキリソレノイド	THREAD TRIMMER SOLENOID	
24	S41202051	1	イトハライソレノイドクミ	THREAD WIPER SOLENOID ASSY	
26	S38148000	1	アースセン1	GROUND WIRE, 1	
27	0A5400806	1	+ナベザクミ4X8DB	SCREW, PAN (S/P WASHER) M4X8	
28	062300612	4	ナベコ3X6	SCREW, PAN M3X6	
29	062300612	2	ナベコ3X6	SCREW, PAN M3X6	
30	021060206	2	2シユナツト6	NUT, 2 M6	
31	028060246	2	バネザガネ2-6	WASHER, SPRING 2-6	
32	S31674000	1	コネクタ3191-09P	CONNECTOR, 3191-09P	
33	149809000	1	タイラツPL	BEAD BAND, L = 200	
34	340400001	1	ユニタイバンド	BEAD BAND	
35-1	S43203000	1	EMスイッチクミ	EM-SWITCH ASSY	
37	S25664000	3	コードホルダ#6	CORD HOLDER, 6N	
38	0A5400806	4	+ナベザクミ4X8DB	SCREW, PAN (S/P WASHER) M4X8	
39	228475000	2	ケツソクバンド1.9X80	FASTENING BAND, 1.9X80	
40	340400001	4	ユニタイバンド	BEAD BAND	
44-2	S00480000	1	コードホルダ#5	CORD HOLDER, 5N	
45	149809000	1	タイラツPL	BEAD BAND, L = 200	
22	S43198101	1	<BAS-311E電磁式用> オサエソレノイドクミ	<For solenoid type of BAS-311E> CLAMP SOLENOID ASSY	
25	004501003	4	+サラコ5X10	SCREW, FLAT M5X10	
44-1	S25664000	1	コードホルダ#6	CORD HOLDER, 6N	
41	018401222	4	<311ELモータX--固定用> アナボルト4X12	<For setting the motor X of BAS-311EL> BOLT, SOCKET M4X12	
42	025040232	4	ヒラザガネチユウ4	WASHER, PLAIN M 4	
43	028040242	4	バネザガネ2.4	WASHER, SPRING 2-4	
35-2	S43204000	1	" オプション部品 "	" OPTION PARTS "	
36	S37057001	1	EM口ツクスイッチクミ	EM LOCK-SWITCH ASSY	
		1	EMスイッチスペーサ3	EM-SWITCH SPACER, 3	

From the library of: Diamond Needle Corp

Q. 針位置検出器関係 / Synchronizer / Synchronisator / Synchronisateur / Sincronizador

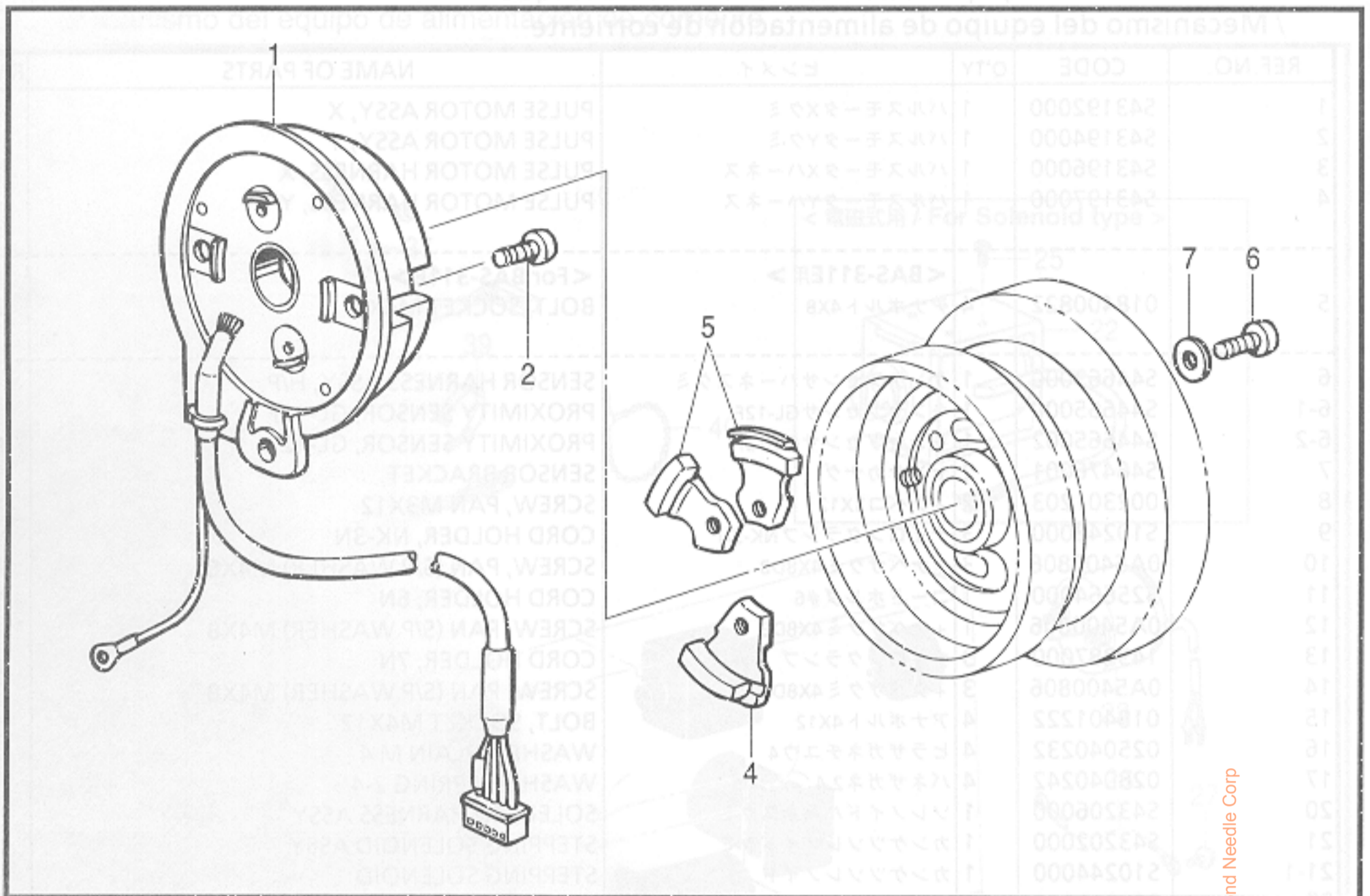

R. プリント基板関係 / Printed circuit board mechanism / Leiterplatten / Circuits imprimés / Tableros de circuitos impresos

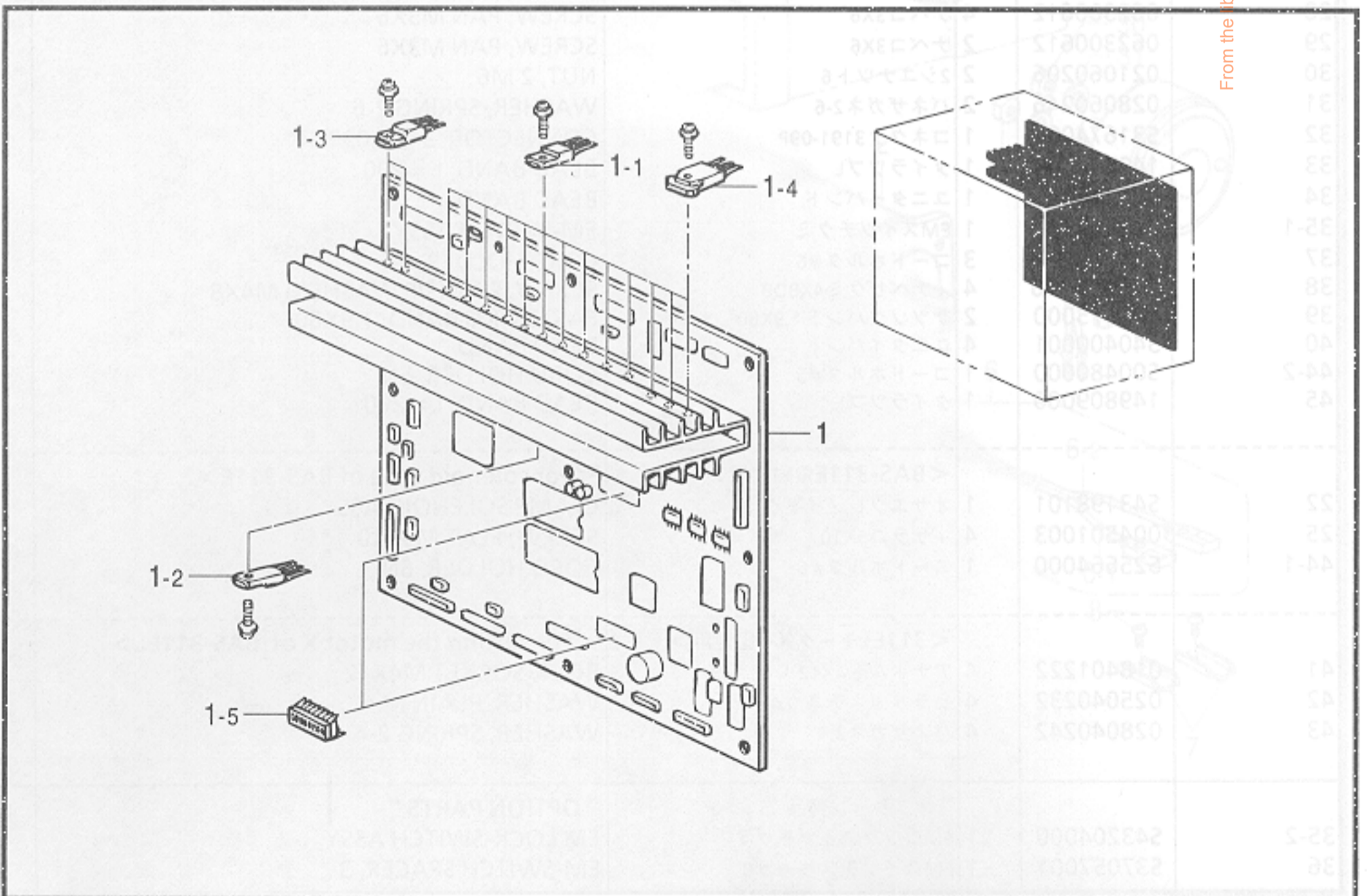

151-V11-501

From the library of: Diamond Needle Corp

151-V11-518

Q. 針位置検出器関係 / Synchronizer / Synchronisator / Synchronisateur / Sincronizador

REF.NO.	CODE	Q'TY	ヒンメイ	NAME OF PARTS	RM
1	S38072201	1	シンクロナイザクミ	SYNCRONIZER ASSY	
2	062400806	2	ナベコ4X8	SCREW, PAN M4X8	
4	S38080001	1	ハリシタジシヤククミ	MAGNET ASSY, D	
5	S38082001	2	ハリウエジシヤククミ	MAGNET ASSY, U	
6	062681412	3	ナベコ437-40X14	SCREW, PAN SM4.37-40X14	
7	025680132	3	ヒラザガネシヨウ4.37	WASHER, PLAIN S 4.37	
-2.3	S34870001	1	DIP SW	DIP SWITCH:KSP08	
-2.4	S38104000	1	エンコーダ	ENCODER, EVQVEMF01	
-2.5	417882001	1	ブザー	BUZZER:PKB245C-3601	
-3	S43216000	1	ケーブル	PCB HARNESS	
-4	S43220000	1	ケーブル	PANEL HARNESS ASSY, P	
-5	0A5400800	4	ナベコ	SCREW, PAN (S/P WASHER) M4X8	
-6	0A4300600	4	ナベコ	SCREW, PAN (S/P WASHER) M3X6	
-7	S43237000	1	ROM	PROM PANEL ASSY	
-8	S02907000	1	ダイヤル	DIAL	
-9	S43224000	1	スペーサ	SPACER, R05	
-10	S43225000	2	スペーサ	SPACER, R05	
-11	0A4300605	4	ナベコ	SCREW, PAN (S/P WASHER) M3X6	
-12	037300816	4	ナベコ	TAPPING SCREW, PAN V M3X8	
-13	S43228000	1	プログラマ	PROGRAMMER HARNESS ASSY, P	
-14	007300603	2	ナベコ	SCREW, PAN M3X6	
-15	S42653000	2	コア	CORE TFC-23-11-14	
-16	149809000	2	ビーズ	BEAD BAND, L=200	
-17	008400604	8	ナベコ	SCREW, TRUSS M4X6	
-18	S36000009	1	パネル	PANEL SIDE COVER	
-19	107321009	1	ナベコ	SHOULDER SCREW, SM4 76	
-20	107017001	1	ナベコ	WASHER, SPRING WAVE	

151-V11-501

R. プリント基板関係 / Printed circuit board mechanism / Leiterplatten / Circuits imprimés / Tableros de circuitos impresos

REF.NO.	CODE	Q'TY	ヒンメイ	NAME OF PARTS	RM
1	S43210001	1	セイギヨキバンクミ	CONTROL PCB ASSY	
1-1	U38337000	10	FET2SJ350	TRANSISTOR, FET:2SJ350	
1-2	U38338000	10	FET2SK2202	TRANSISTOR, FET:2SK2202	
1-3	S38155000	4	MOSFET2SK1306	MOS FET, 2SK1306	
1-4	S38164000	6	MOSFET2SK1937	MOS FET, 2SK1937	
1-5	U32744000	2	DIPSWDSS708	DIP SWITCH:DSS708	
10	S45199000	1	ケーブル	ケーブル	
11	200190001	2	ケーブル	ケーブル	

151-V11-518

S. 操作パネル関係 / Operation panel mechanism / Schaltkasten
 / Mécanisme du boîtier de contrôle / Mecanismo del caja de controles

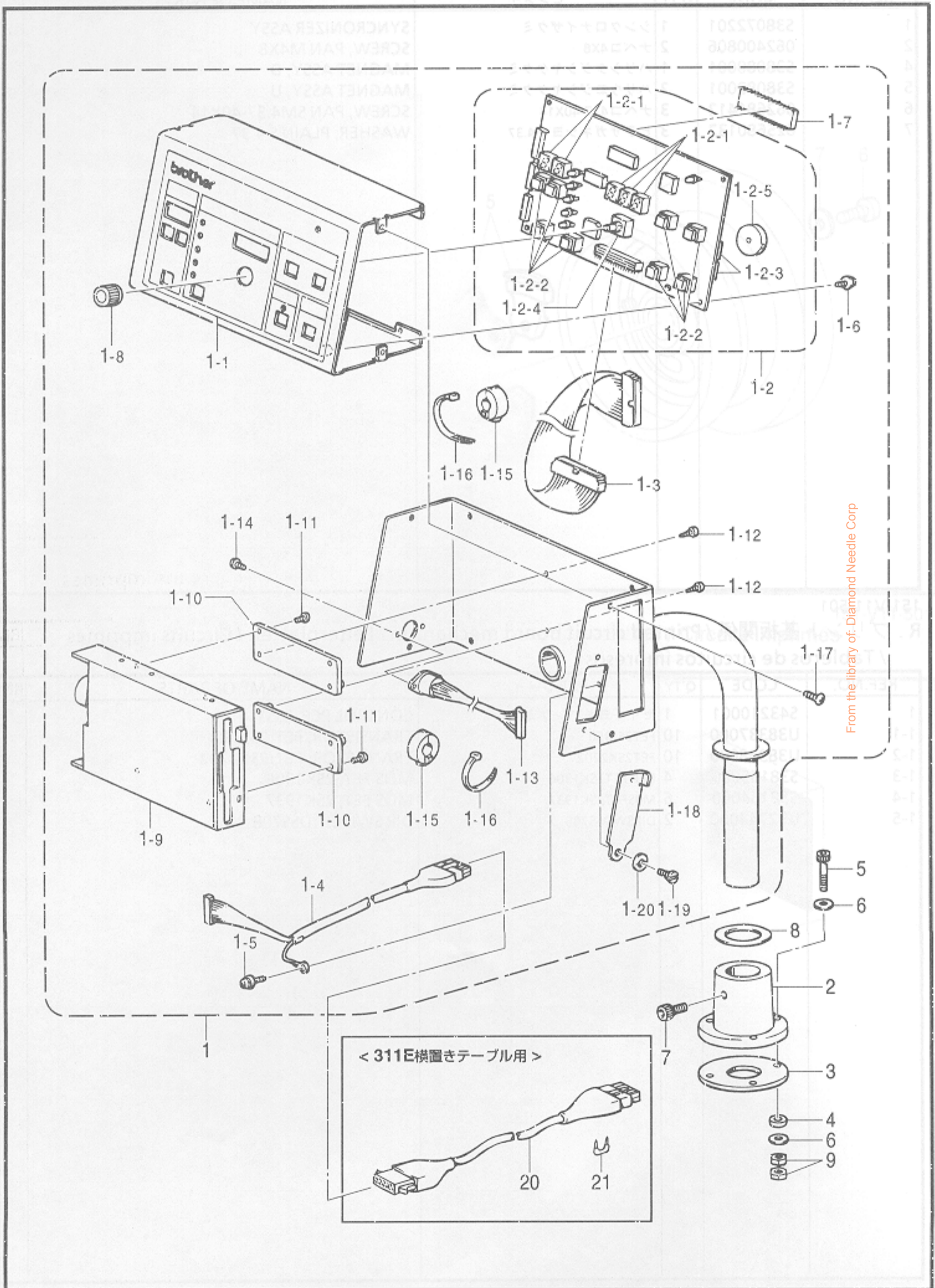

From the library of: Diamond Needle Corp

S. 操作パネル関係 / Operation panel mechanism / Schaltkasten
 / Mécanisme du boîtier de contrôle / Mecanismo del caja de controles

REF.NO.	CODE	Q'TY	ヒンメイ	NAME OF PARTS	RM
1	S43220209	1	ソウサパネルクミ	OPERATION PANEL ASSY	
1-1	S43223009	1	ソウサパネルフィルム	FILM, OPERATION PANEL	
1-2	S43229001	1	パネルキバンクミ	PANEL PCB ASSY	
1-2-1	S29023000	5	LEDGL9P040	LED, GL9P040	
1-2-2	S30260002	8	SWDP1-100	SWDP1-100, GRAY	
1-2-3	U34870001	2	DIPSW KSP08	DIP SWITCH:KSP08	
1-2-4	S38104000	1	エンコーダEVQVEMF01	ENCODER, EVQVEMF01	
1-2-5	417382001	1	PKB24SC-3601	BUZZER:PKB24SC-3601	
1-3	S43226000	1	FDDハーネス	FDD HARNESS	
1-4	S43227200	1	パネルコードPクミ	PANEL HARNESS ASSY, P	
1-5	0A5400805	1	+ナベザクミ4X8DB	SCREW, PAN (S/P WASHER) M4X8	
1-6	0A4300605	4	+ナベザクミ3X6DA	SCREW, PAN (S/P WASHER) M3X6	
1-7	S43237000	1	PROMパネルクミ	PROM PANEL ASSY	
1-8	S02907000	1	ツマミ	DIAL	
1-9	S43224000	1	3.5FDD	FDD, 3.5	
1-10	S43225000	2	FDDスペーサ	SPACER, FDD	
1-11	0A4300605	4	+ナベザクミ3X6DA	SCREW, PAN (S/P WASHER) M3X6	
1-12	037300816	4	Vナベタツピン3X8	TAPPING SCREW, PAN V M3X8	
1-13	S43228000	1	プログラマコードPクミ	PROGRAMMER HARNESS ASSY, P	
1-14	002300603	2	+ナベコ3X6	SCREW, PAN M3X6	
1-15	S42653000	2	コアTFC-23-11-14	CORE, TFC-23-11-14	
1-16	149809000	2	タイラツプル	BEAD BAND, L = 200	
1-17	008400604	8	+トラスコ4X6	SCREW, TRUSS M4X6	
1-18	S36008009	1	パネルヨコカバー	PANEL SIDE COVER	
1-19	107321009	1	ダンネジ4.76	SHOULDER SCREW, SM4.76	
1-20	107017001	1	ナミバネザガネ	WASHER, SPRING WAVE	
2	S43236009	1	ソウサパネルドダイ	OPERATION PANEL BASE	
3	S43674000	1	クツシヨンA	CUSHION, A	
4	S43675000	3	クツシヨンB	CUSHION, B	
5	S25634101	3	アナボルト5X65	BOLT, SOCKET M5X65	
6	025050236	6	ヒラザガネチユウ5	WASHER, PLAIN M 5	
7	018081636	1	アナボルト8X16	BOLT, SOCKET M8X16	
8	S10408000	1	ゴムシート	RUBBER SHEET	
9	021500106	6	1シユナツト5	NUT, 1 M5	
20	S45199000	1	" オプション部品 "	" OPTION PARTS "	
21	200190001	3	<311E横置きテーブル用> パネルエンテヨウコードクミ ステツプル	<For Japan only> FASTENING BAND, 1.9X80 FOOT PETAL PEDAL PROTECTION PLATE SPRING, PLATE WASHER, SPRING 2-3 WASHER, PLAIN M5 FOOT PEDAL SHAFT RETAINING RING, F5 SCREW, PAN (S/P WASHER) M4X6 RUBBER CAP, 9.4 CONNECTOR CAP, 172169-1 CONNECTOR CAP, 18X19 RUBBER CAP, NG79F	

From the library of: Diamond Needle Corp

< 311E電磁式用 / For Solenoid type of 311E >

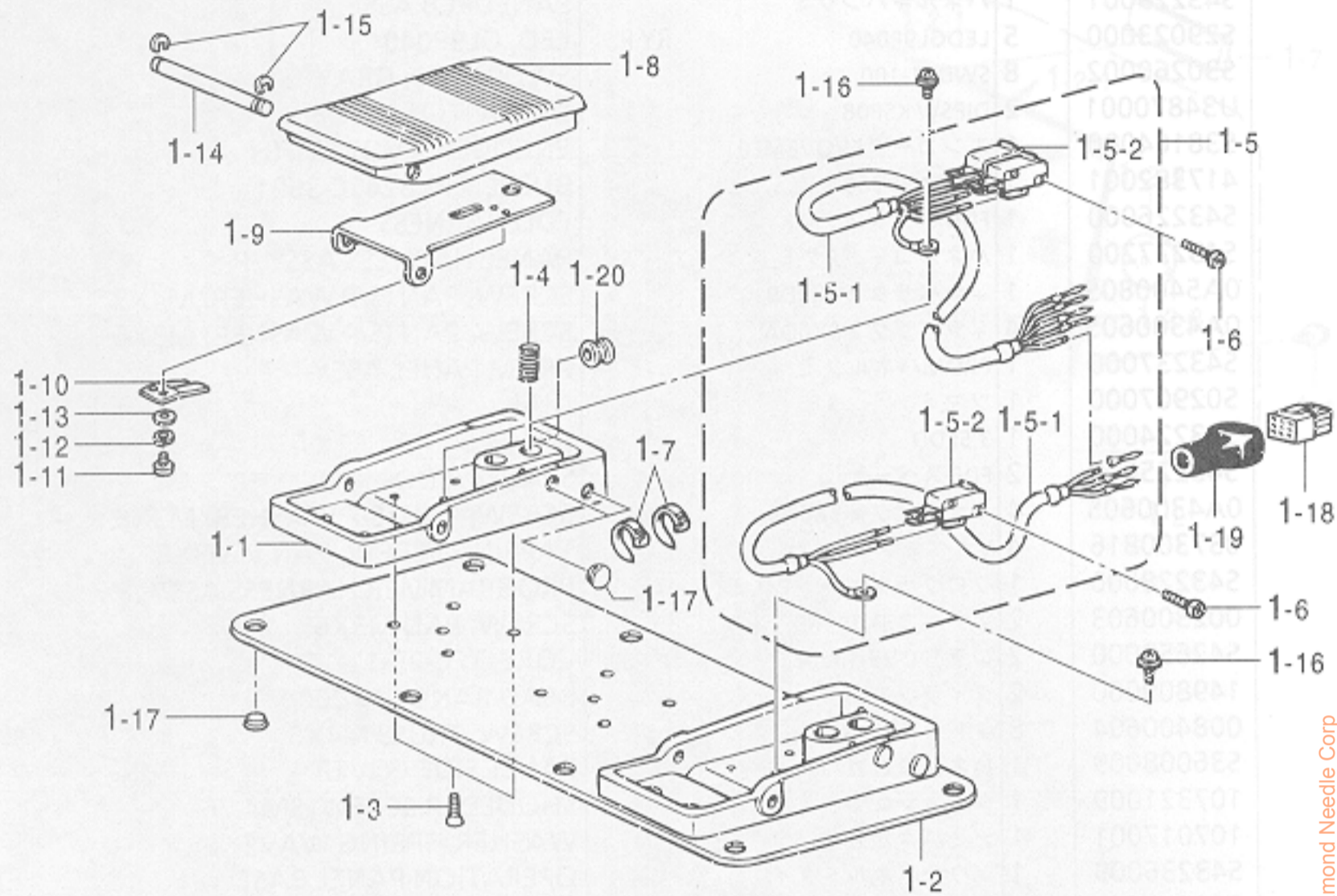

From the library of: Diamond Needle Corp

< エアー式用 / For Pneumatic type >

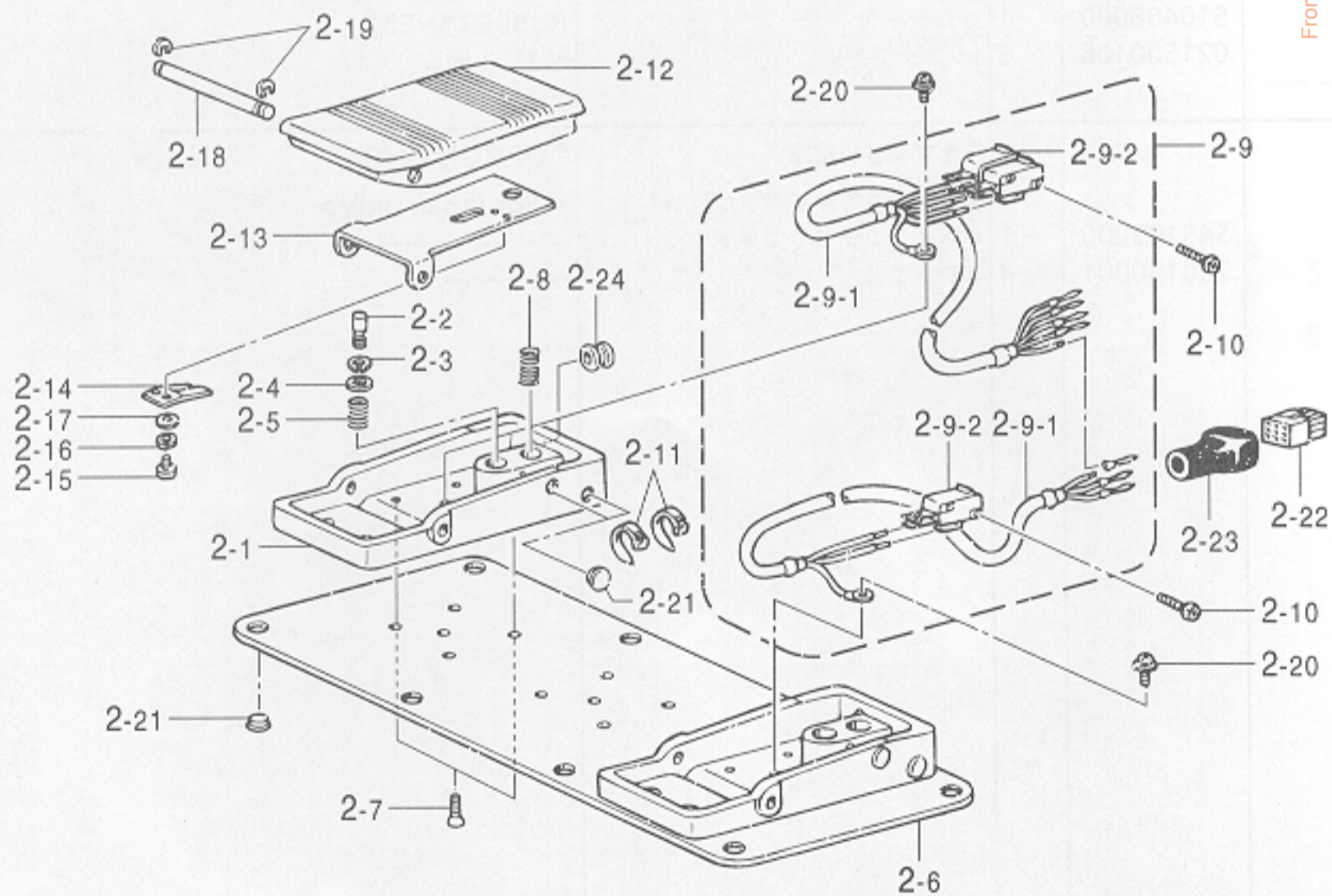

T1. 踏板関係 / Foot switch pedal mechanism / Fußbetätigung / Mécanisme de la pédale / Mecanismo del pedal

REF.NO.	CODE	Q'TY	ヒンメイ	NAME OF PARTS	RM
			<BAS-311E電磁式用>	<For Solenoid type of BAS-311E>	
1	S42838001	1	2レンフット2SW	2-PEDAL FOOT SWITCH, 2	
1-1	S38166000	2	フットペダルダイ	FOOT PEDAL BASE	
1-2	S42867001	1	フミイタホジヨイタ	TREADLE AUXILIARY PLATE	
1-3	004400603	8	+サラコネジ4X6	SCREW, FLAT M4X6	
1-4	S38170001	2	フットペダルバネ	SPRING, COMPRESSION	
1-5	S38029000	1	2レンフットSWハーネスクミ	2-PEDAL FOOT SW HARNESS ASSY	
1-5-1	S38030000	1	2レンフットSWハーネス	2-PEDAL FOOT SW HARNESS	
1-5-2	S36260000	2	スイッチVXピンボタン	SWITCH PIN BUTTON, VX	
1-6	062301205	4	ナベコ3X12	SCREW, PAN M3X12	
1-7	228475000	10	ケツソクバンド1.9X80	FASTENING BAND, 1.9X80	
1-8	S38174000	2	フットペダル	FOOT PEDAL	
1-9	S38175001	2	ペダルホゴイタ	PEDAL PROTECTION PLATE	
1-10	S38176001	2	スイッチオサエバネ	SPRING, PLATE	
1-11	002300403	4	+ナベコ3X4	SCREW, PAN M3X4	
1-12	028030246	4	バネザガネ2-3	WASHER, SPRING 2-3	
1-13	025030236	4	ヒラザガネチユウ3	WASHER, PLAIN M 3	
1-14	S38177001	2	フットペダルジク	FOOT PEDAL SHAFT	
1-15	048050346	4	トメワE5	RETAINING RING, E5	
1-16	052400606	2	ナベコバネヒラ4X6	SCREW, PAN (S/P WASHER) M4X6	
1-17	117936001	12	ゴムセン9.4	RUBBER CAP, 9.4	
1-18	S38180000	1	コネクタ172169-1	CONNECTOR, 172169-1	
1-19	S38060000	1	コネクタキャップ18X19	CONNECTOR CAP, 18X19	
1-20	S38059000	2	グロメットNG79F	RUBBER CAP, NG79F	
			<311E, 311ELエア-式用>	<For Pneumatic type of 311E & 311EL>	
2	S42842001	1	2レンフット3SW	2-PEDAL FOOT SWITCH, 3	
2-1	S38166000	2	フットペダルダイ	FOOT PEDAL BASE	
2-2	S38167001	1	2ダンSWピン	SWITCH PIN, 2-STEP	
2-3	048060142	1	トメワジクヨウC6	RETAINING RING, C6	
2-4	025060236	1	ヒラザガネチユウ6	WASHER, PLAIN M 6	
2-5	S38168001	1	アツシユクバネ	SPRING, COMPRESSION	
2-6	S42867001	1	フミイタホジヨイタ	TREADLE AUXILIARY PLATE	
2-7	004400603	4	+サラコネジ4X6	SCREW, FLAT M4X6	
2-8	S38170001	2	フットペダルバネ	SPRING, COMPRESSION	
2-9	S42259000	1	2レンフット3SWハーネスクミ	2-PEDAL FOOT SW HARNESS ASSY, 3	
2-9-1	S42258000	1	2レンフット3SWハーネス	2-PEDAL FOOT SW HARNESS, 3	
2-9-2	S36260000	3	スイッチVXピンボタン	SWITCH PIN BUTTON, VX	
2-10	062301205	4	ナベコ3X12	SCREW, PAN M3X12	
2-11	228475000	10	ケツソクバンド1.9X80	FASTENING BAND, 1.9X80	
2-12	S38174000	2	フットペダル	FOOT PEDAL	
2-13	S38175001	2	ペダルホゴイタ	PEDAL PROTECTION PLATE	
2-14	S38176001	2	スイッチオサエバネ	SPRING, PLATE	
2-15	002300403	4	+ナベコ3X4	SCREW, PAN M3X4	
2-16	028030246	4	バネザガネ2-3	WASHER, SPRING 2-3	
2-17	025030236	4	ヒラザガネチユウ3	WASHER, PLAIN M 3	
2-18	S38177001	2	フットペダルジク	FOOT PEDAL SHAFT	
2-19	048050346	4	トメワE5	RETAINING RING, E5	
2-20	052400606	2	ナベコバネヒラ4X6	SCREW, PAN (S/P WASHER) M4X6	
2-21	117936001	12	ゴムセン9.4	RUBBER CAP, 9.4	
2-22	S38180000	1	コネクタ172169-1	CONNECTOR, 172169-1	
2-23	S38060000	1	コネクタキャップ18X19	CONNECTOR CAP, 18X19	
2-24	S38059000	2	グロメットNG79F	RUBBER CAP, NG79F	

From the library of: Diamond Needle Corp

T2 . 踏板関係 (オプション部品) / Foot switch pedal mechanism (Option parts)
 / Fußbetätigung (Sonderzubehör) / Mécanisme de la pédale (Pièces en option)
 / Mecanismo del pedal (Piezas opcionales)

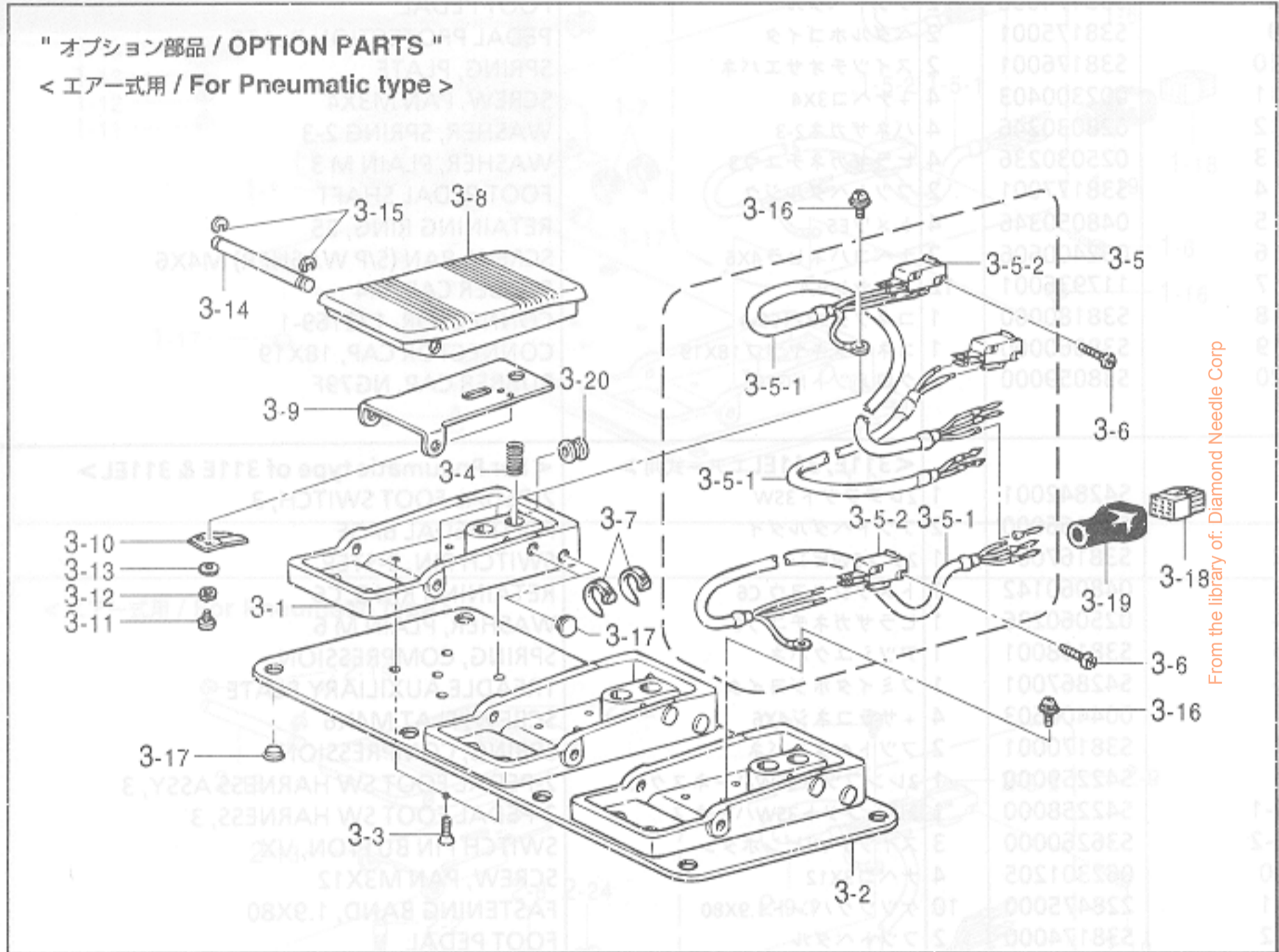

T2. 踏板関係 (オプション部品) / Foot switch pedal mechanism (Option parts)
 / Fußbetätigung (Sonderzubehör) / Mécanisme de la pédale (Pièces en option)
 / Mecanismo del pedal (Piezas opcionales)

REF.NO.	CODE	Q'TY	ヒンメイ	NAME OF PARTS	RM
			<311E, 311ELエアース用>	<For Pneumatic type of 311E & 311EL>	
3	S44805001	1	3レンフット3SW	3-PEDAL FOOT SWITCH, 3	
3-1	S38166000	3	フットペダルダイ	FOOT PEDAL BASE	
3-2	S42867001	1	フミイタホジヨイタ	TREADLE AUXILIARY PLATE	
3-3	004400603	12	+サラコネジ4X6	SCREW, FLAT M4X6	
3-4	S38170001	3	フットペダルバネ	SPRING, COMPRESSION	
3-5	S44806000	1	3レンフットSWハーネスクミ	3-PEDAL FOOT SW HARNESS ASSY	
3-5-1	S44807000	1	3レンフットSWハーネス	3-PEDAL FOOT SW HARNESS	
3-5-2	S36260000	3	スイッチVXピンボタン	SWITCH PIN BUTTON, VX	
3-6	062301205	6	ナベコ3X12	SCREW, PAN M3X12	
3-7	228475000	10	ケツソクバンド1.9X80	FASTENING BAND, 1.9X80	
3-8	S38174000	3	フットペダル	FOOT PEDAL	
3-9	S38175001	3	ペダルホゴイタ	PEDAL PROTECTION PLATE	
3-10	S38176001	3	スイッチオサエバネ	SPRING, PLATE	
3-11	002300403	6	+ナベコ3X4	SCREW, PAN M3X4	
3-12	028030246	6	バネザガネ2-3	WASHER, SPRING 2-3	
3-13	025030236	6	ヒラザガネチユウ3	WASHER, PLAIN M 3	
3-14	S38177001	3	フットペダルジク	FOOT PEDAL SHAFT	
3-15	048050346	6	トメワE5	RETAINING RING, E5	
3-16	052400606	2	ナベコバネヒラ4X6	SCREW, PAN (S/P WASHER) M4X6	
3-17	117936001	14	ゴムセン9.4	RUBBER CAP, 9.4	
3-18	S38180000	1	コネクタ172169-1	CONNECTOR, 172169-1	
3-19	S38060000	1	コネクタキャップ18X19	CONNECTOR CAP, 18X19	
3-20	S38059000	3	グロメットNG79F	RUBBER CAP, NG79F	

From the library of: Diamond Needle Corp

U1 . 動力台関係 (国内用) / Power table (For Japan only) / Motorgestell
 / Mécanisme du plateau de la machine / Mecanismo de la mesa de la máquina

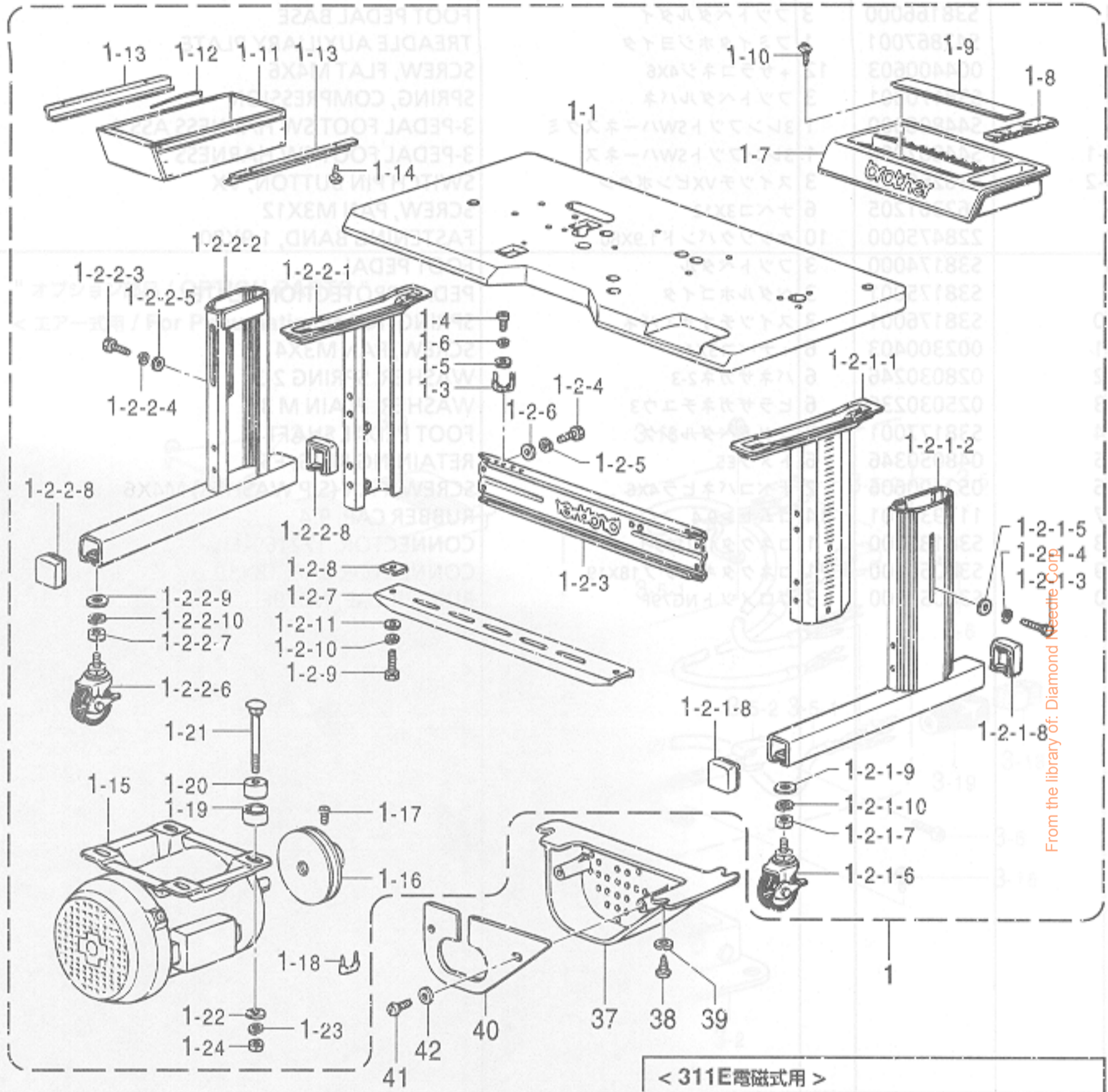

From the library of: Diamond Needle Corp.

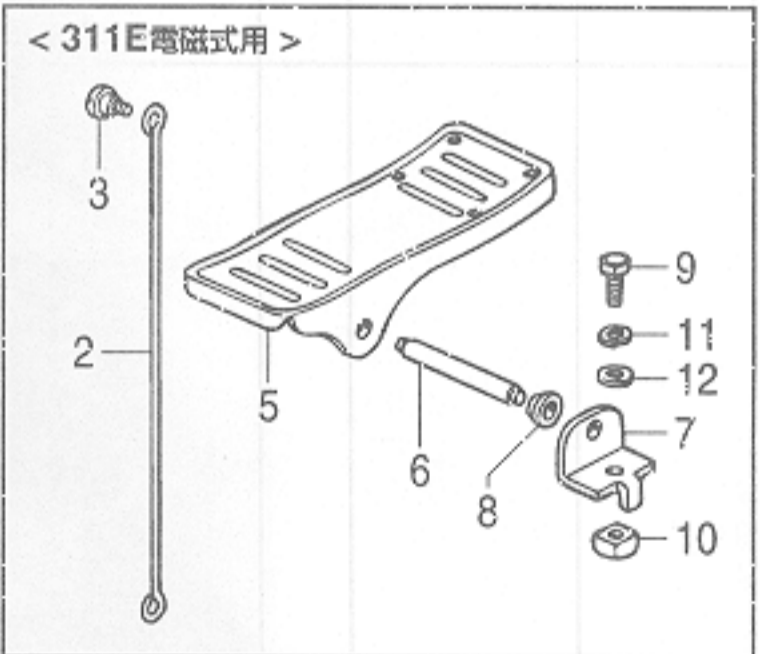
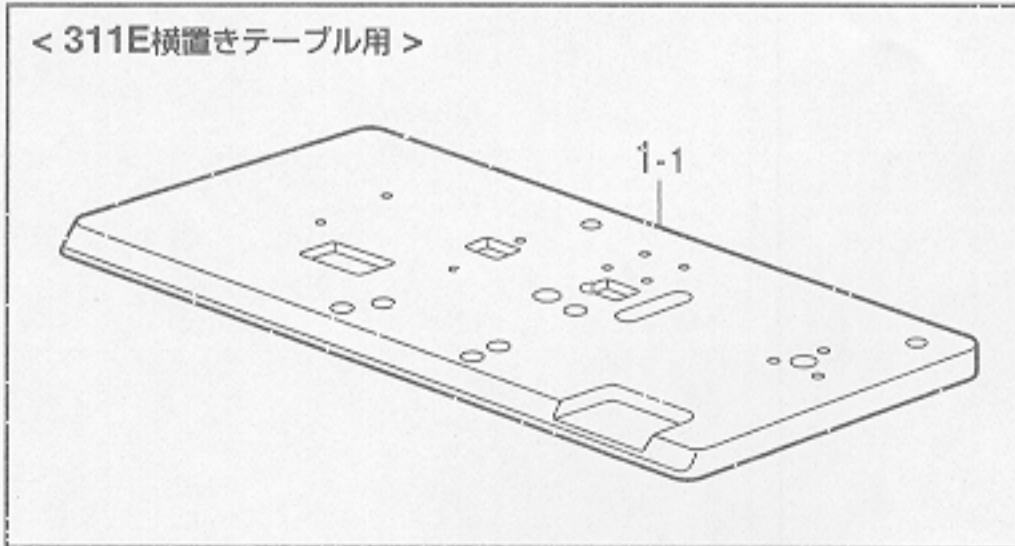

U1. 動力台関係 (国内用) / Power table (For Japan only) / Motorgestell (国内用) 兼開台機構 / Mécanisme du plateau de la machine / Mecanismo de la mesa de la máquina

REF.NO.	CODE	Q'TY	ヒンメイ	NAME OF PARTS	RM
1-18	200190001	5	"国内標準テーブル用"	"For Japan only"	
1	S42850409	1	311テーブルキヤククミ	-----	
1-1	S42851301	1	311テーブル	-----	
1-21	133740006	4	4カクナット	-----	
1-23	028080246	3	3バネザガネ2-8	-----	
1-24	028080246	3	3バネザガネ2-8	-----	
1	S42852309	1	311テーブルキヤクヨコクミ	-----	
1-1	S42853201	1	311テーブルヨコ	-----	

<国内用共通部品>					
1-2	S43671109	1	タチヨウキヤククミ	-----	
1-2-1	S09639009	1	タチキヤククミ	-----	
1-2-1-1	S09216002	1	テーブルササエR	-----	
1-2-1-2	S09217102	1	ソトアシR	-----	
1-2-1-3	017081606	3	ボルト8X16	-----	
1-2-1-4	028080246	3	バネザガネ2-8	-----	
1-2-1-5	S09312001	3	ヒラザガネダイ8	-----	
1-2-1-6	S05223001	2	キヤスター	-----	
1-2-1-7	022120306	2	ナツト3シユ12	-----	
1-2-1-8	S10661109	2	ソトアシフタゴム	-----	
1-2-1-9	026120236	2	ヒラザガネミガキ12	-----	
1-2-1-10	028120246	2	バネザガネ2-12	-----	
1-2-2	S09640009	1	タチキヤククミ	-----	
1-2-2-1	S09221002	1	テーブルササエL	-----	
1-2-2-2	S09222102	1	ソトアシL	-----	
1-2-2-3	017081606	3	ボルト8X16	-----	
1-2-2-4	028080246	3	バネザガネ2-8	-----	
1-2-2-5	S09312001	3	ヒラザガネダイ8	-----	
1-2-2-6	S05223001	2	キヤスター	-----	
1-2-2-7	022120306	2	ナツト3シユ12	-----	
1-2-2-8	S10661109	2	ソトアシフタゴム	-----	
1-2-2-9	026120236	2	ヒラザガネミガキ12	-----	
1-2-2-10	028120246	2	バネザガネ2-12	-----	
1-2-3	S43672109	1	ハリ	-----	
1-2-4	017081606	4	ボルト8X16	-----	
1-2-5	028080246	4	バネザガネ2-8	-----	
1-2-6	025080236	4	ヒラザガネチユウ8	-----	
1-2-7	S09224002	1	フミイタササエダイ	-----	
1-2-8	S09225001	2	4カクナツト	-----	
1-2-9	017081606	2	ボルト8X16	-----	
1-2-10	028080246	2	バネザガネ2-8	-----	
1-2-11	S09226001	2	フミイタササエザガネ	-----	
1-3	133172003	1	アブラサシダイ	-----	
1-4	037521016	1	+ナベタツピン2シユ5	-----	
1-5	025050236	1	ヒラザガネチユウ5	-----	
1-6	028050246	1	バネザガネ2-5	-----	
1-7	S15158009	1	コモノケース	-----	
1-8	S02740000	1	フェルト	-----	
1-9	S02739000	1	ゴムジヤクテープ	-----	
1-10	039411215	2	1トラスタツピン4X12	-----	
1-11	119702004	1	ヨコヒキダシ	-----	
1-12	101073001	1	ヒキダシコテイバネ	-----	
1-13	101121000	2	ヨコヒキダシササエ	-----	
1-14	032361306	4	+マルモクネジ3.5X13	-----	
1-15	S46460000	1	3ソウ400Wモータ200V	-----	
1-16	S38041000	1	モータプーリ	-----	
1-17	105073001	1	アタマツキトメネジ5.95	-----	

From the library of: Diamond Needle Corp

U1 . 動力台関係 (国内用) / Power table (For Japan only) / Motorgestell
 / Mécanisme du plateau de la machine / Mecanismo de la mesa de la máquina

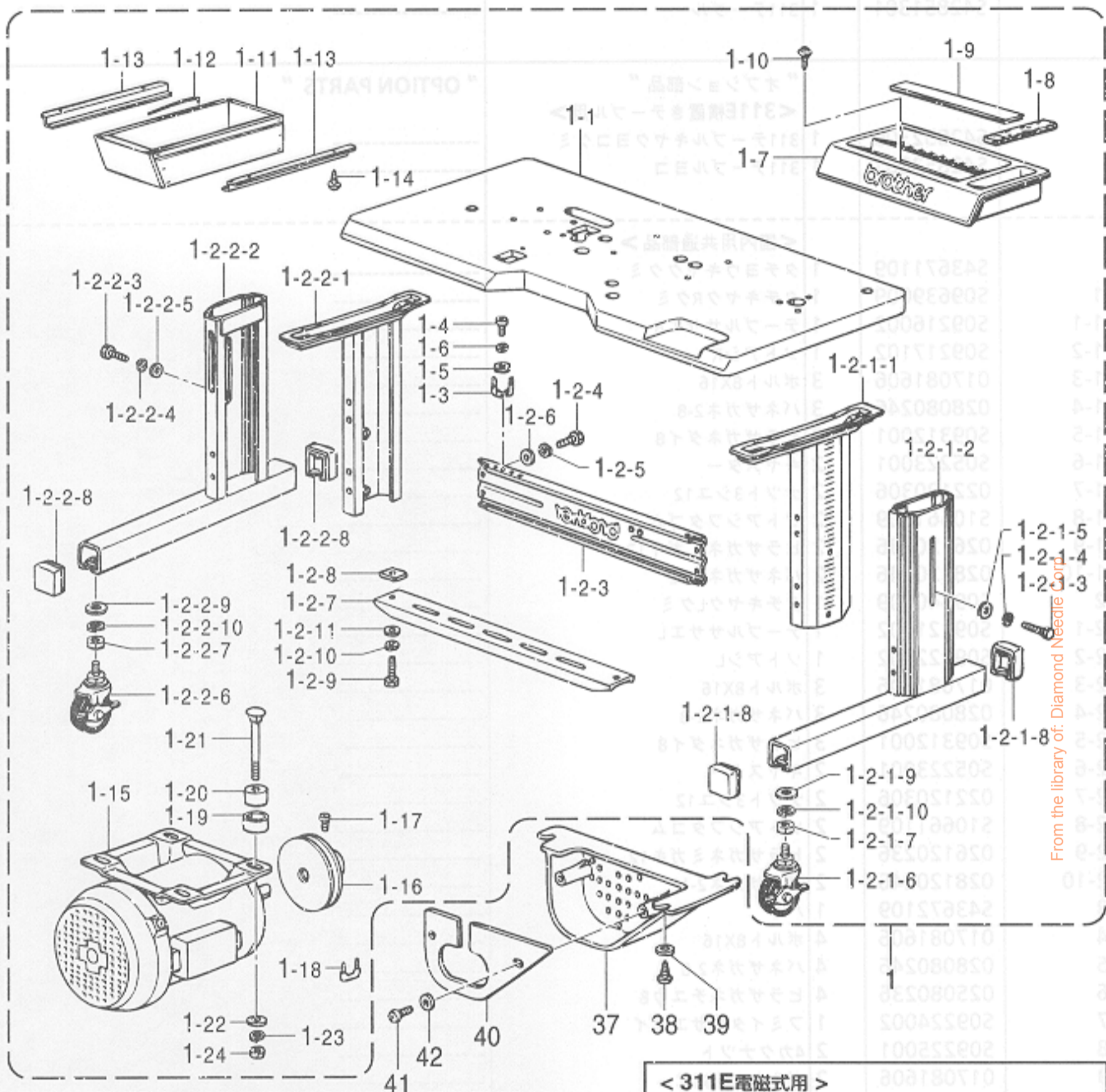

From the library of: Diamond Needle Cord

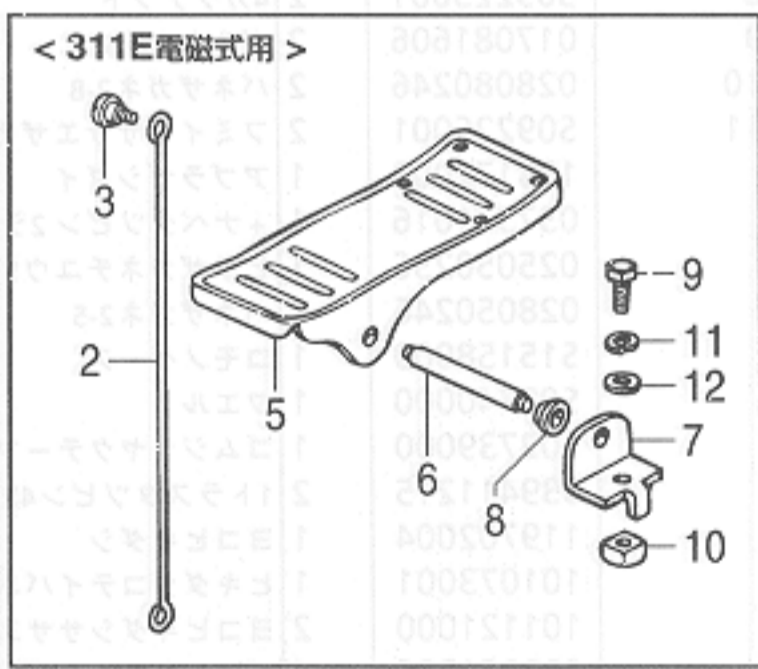
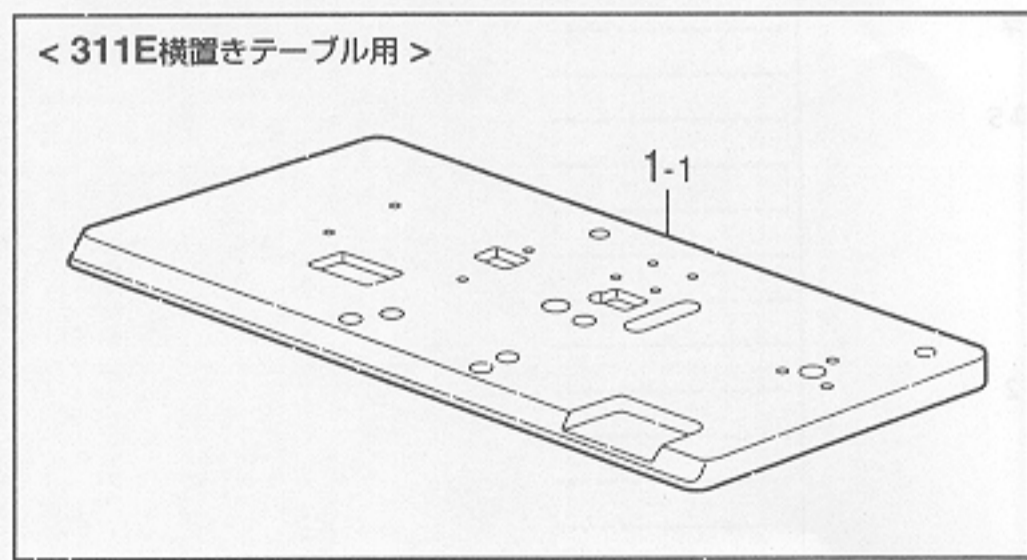

U1. 動力台関係 (国内用) / Power table (For Japan only) / Motorgestell (用出脚) 脚台式機 . SU
 / Mécanisme du plateau de la machine / Mecanismo de la mesa de la máquina

REF.NO.	CODE	Q'TY	ヒンメイ	NAME OF PARTS	RM
1-18	200190001	5	ステツプル	-----	
1-19	146256001	4	クツシヨンカナグ	-----	
1-20	146255000	4	クツシヨン	-----	
1-21	133740006	4	カクネボルト6X70	-----	
1-22	025060336	4	ヒラザガネダイ6	-----	
1-23	028060246	4	バネザガネ2-6	-----	
1-24	021060106	4	1シユナツト6	-----	
37	518633109	1	モータカバー	-----	
38	032422003	3	+マルモクネジ4.1X20	-----	
39	116662003	3	ザガネ	-----	
40	S20137001	1	モーターウシロカバー	-----	
41	138444001	2	ナベBタイト4X14	-----	
42	025040232	2	ヒラザガネチユウ4	-----	
2	S02337001	1	<電磁式用> オサエアゲレンカン	-----	
3	115559002	1	ダンネジ4.76	-----	
5	S01199003	1	オサエアゲフミイタ	-----	
6	133188001	1	オサエアゲフミイタジク	-----	
7	119707003	2	フミイタジクウケ	-----	
8	119708001	2	フミイタジクウケカラー	-----	
9	017082206	2	ボルト8X22	-----	
10	116694001	2	4カクナツト8	-----	
11	028080240	2	バネザガネ2-8	-----	
12	025080236	2	ヒラザガネチユウ8	-----	

From the library of: Diamond Needle Corp

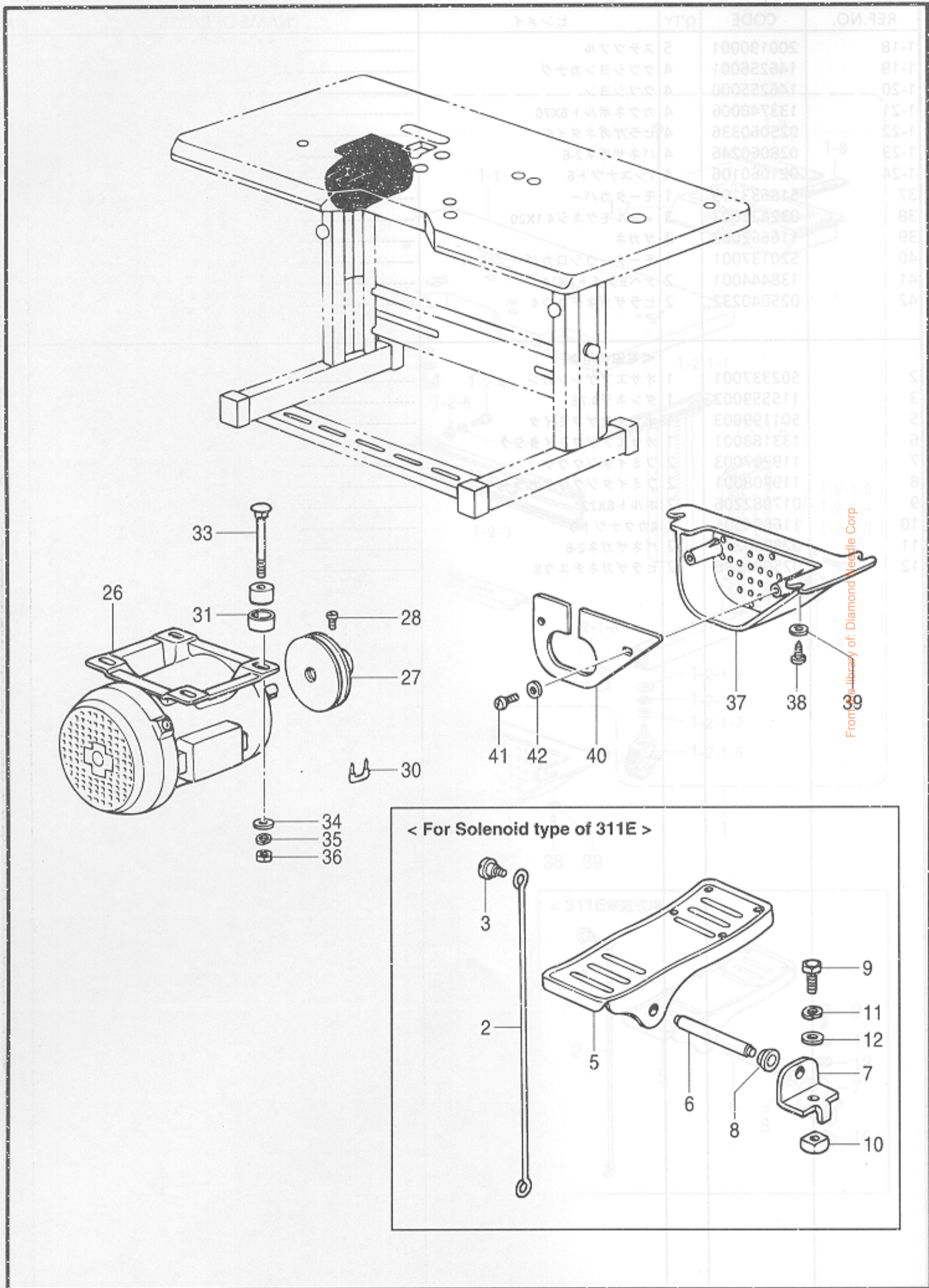

From the library of: Diamond Needle Corp.

U2 . 動力台関係 (輸出用) / Power table (For Export) / Motorgesteil
 / Mécanisme du plateau de la machine / Mecanismo de la mesa de la máquina

REF.NO.	CODE	Q'TY	ヒンメイ	NAME OF PARTS	RM
			<電磁式用>	<For Solenoid type>	
2	S02337001	1	オサエアゲレンカン	WORK CLAMP LIFTER CONNECT. ROD	
3	115559002	1	ダンネジ4.76	SHOULDER SCREW, SM4.76	
5	S01199003	1	オサエアゲフミイタ	TREADLE PEDAL	
6	133188001	1	オサエアゲフミイタジク	TREADLE SHAFT	
7	119707003	2	フミイタジクウケ	TREADLE SHAFT BRACKET	
8	119708001	2	フミイタジクウケカラー	TREADLE SHAFT BRACKET COLLAR	
9	017082206	2	ボルト8X22	BOLT, M8X22	
10	116694001	2	4カクナツト8	NUT, M8	
11	028080240	2	バネザガネ2-8	WASHER, SPRING 2-8	
12	025080236	2	ヒラザガネチユウ8	WASHER, PLAIN M 8	
			<輸出用共通部品>	<Common parts for export>	
26	S46460000	1	3ソウ400Wモータ200V	MOTOR, 3-PHASE 200V-400W	
27	S38041000	1	モータプーリ	MOTOR PULLEY	
28	105073001	1	アタマツキトメネジ5.95	SET SCREW, SM5.95	
30	200190001	5	ステツブル	STAPLE	
31	146256001	4	クツシヨンカナダ	CUSHION COLLAR	
32	146255000	4	クツシヨン	CUSHION	
33	133740006	4	カクネボルト6X70	BOLT, M6X70	
34	025060336	4	ヒラザガネダイ6	WASHER, PLAIN L 6	
35	028060246	4	バネザガネ2-6	WASHER, SPRING 2-6	
36	021060106	4	1シユナツト6	NUT, 1 M6	
37	S18633109	1	モータカバー	MOTOR COVER	
38	032422003	3	+マルモクネジ4.1X20	WOOD SCREW, ROUND M4.1X20	
39	116662003	3	ザガネ	WASHER	
40	S20137001	1	モーターウシロカバー	BACK COVER, MOTOR	
41	138444001	2	ナベ8タイト4X14	TAPTITE, PAN B M4X14	
42	025040232	2	ヒラザガネチユウ4	WASHER, PLAIN M 4	
1			PROGRAMMER ASSY	PROGRAMMER ASSY	
1-1	S43250000	1	プログラマー上カバー	TOP COVER, PROGRAMMER	
1-2	S43251000	1	プログラマー下カバー	LOWER COVER, PROGRAMMER	
1-3	S43252000	1	キーボードスペーサ	SPACER, KEYBOARD	
1-4	S43253000	1	キーボードゴムシート	RUBBER SHEET, KEYBOARD	
1-5	S43254000	1	キーボードシート	KEYBOARD SHEET	
1-6	S43255000	1	Vナベタツピン3X10	TAPPING SCREW, PAN V M3X10	
1-7	S43256000	1	LCDカバー	LCD COVER	
1-8	S43257000	1	LCD	LCD	
1-9	S43258000	1	LCDクインバータ	INVERTER, LCD	
1-10	037200615	1	Vナベタツピン2X6	TAPPING SCREW, PAN V M2X6	
1-11	S43271000	1	プログラマーマグネットA	MAGNET A	
1-12	S43272000	1	プログラマーマグネットB	MAGNET B	
1-13	037300615	1	Vナベタツピン3X6	TAPPING SCREW, PAN V M3X6	
1-14	S43281000	1	プログラマーコード	PROGRAMMER HARNESS	
1-15	S43282000	1	インバーターハーネス	INVERTER HARNESS	
1-16	S43283000	1	ケーブルブッシュKR51	CORD BUSH, KR51	
1-17	S43284000	1	プログラマー下カバー	LOWER COVER, PROGRAMMER	
1-18	S43285000	1	プログラマーPCB	PROGRAMMER PCB	
1-19	S43286000	1	PROMプログラマー	PROM PROGRAMMER	
1-20	S40621000	1	EMIコアESD-SR-15	EMI CORE, ESD-SR-15	
1-21	149809000	1	タイラップ	BEAD BAND, L = 200	

From the library of: Diamond Needle Corp

V. スナップ、フック付装置関係 (オプション部品) / Snap fastener and hook attachment device (Option parts)
 / Vorrichtung zum Anbringen Druckknöpfen und Haken (Sonderzubehör)
 / Dispositif à fermeture pression et attache à crochet (Pièces en option)
 / Dispositivo para colocación de broches de presión y ganchos (Piezas opcionales)

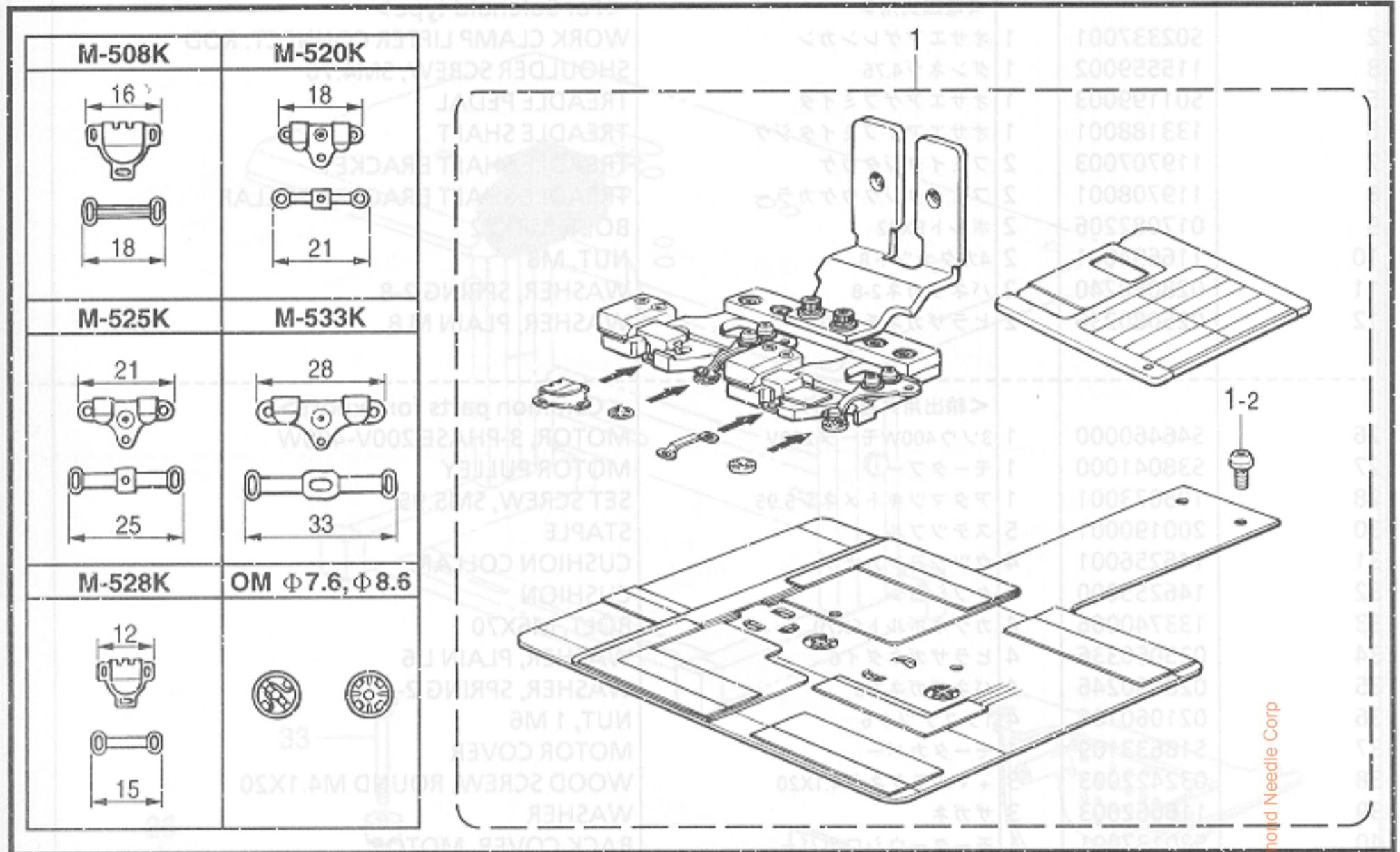

151-V11-940

W. プログラマー関係 (オプション部品) / Programmer (Option parts) / Programmierovrichtung (Sonderzubehör)
 / Programmeur (Pièces en option) / Programador (Piezas opcionales)

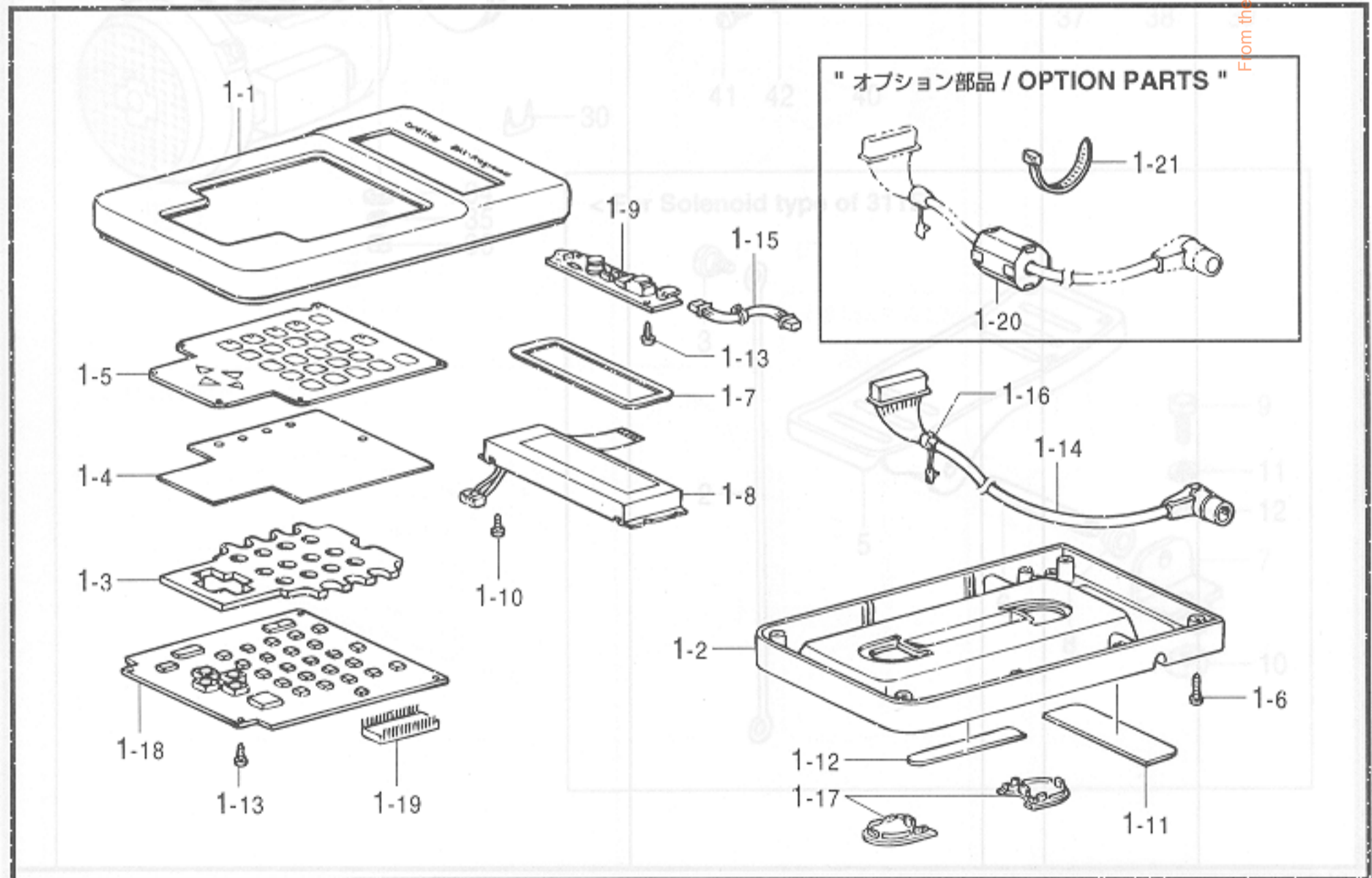

151-V11-942

V. スナップ、フック付装置関係 (オプション部品) / Snap fastener and hook attachment device (Option parts)
 / Vorrichtung zum Anbringen Druckknöpfen und Haken (Sonderzubehör)
 / Dispositif à fermeture pression et attache à crochet (Pièces en option)
 / Dispositivo para colocación de broches de presión y ganchos (Piezas opcionales)

REF.NO.	CODE	Q'TY	ヒンメイ	NAME OF PARTS	RM
1	S42803001	1	<M-508K用> 311-S.Hソウチソウクミ	<For "M-508K"> 311-S.H DEVICE SET	※
1	S42806001	1	<M-528K用> 311-S.Hソウチソウクミ	<For "M-528K"> 311-S.H DEVICE SET	※
1	S42808001	1	<M-520K用> 311-S.Hソウチソウクミ	<For "M-520K"> 311-S.H DEVICE SET	※
1	S42810001	1	<M-525K用> 311-S.Hソウチソウクミ	<For "M-525K"> 311-S.H DEVICE SET	※
1	S42812001	1	<M-533K用> 311-S.Hソウチソウクミ	<For "M-533K"> 311-S.H DEVICE SET	※
1-2	153057002	2	オクリイタシメネジ	SCREW, BUTTON HEAD SM4.37	

151-V11-940

- ☆ RM欄に※が付いている部品は、精密な組立て調整がして有りますので絶対に分解しないで下さい。
 ☆ Parts which have an asterisk (※) in the RM column are parts which have been assembled and adjusted to high precisions. These parts should never be disassembled.
 ☆ Die in der Kolonne RM mit einem Asteriskus (※) bezeichneten Teile sind mit hoher präzision zusammengebaut und eigestellt worden. Aus diesem Grunde dürfen diese Teile niemals zerlegt werden.
 ☆ Les pièces désignées par un astérisque (※) dans la colonne RM sont des pièces qui ont été assemblées et réglées avec une grande précision. Il ne faut en aucun cas déposer ces pièces.
 ☆ Las partes que tienen un asterisco (※) en la columna RM son las partes que han sido armadas y ajustadas a alta precisión. Estas partes nunca deberán ser desarmadas.

W. プログラマー関係 (オプション部品) / Programmer (Option parts) / Programmier Vorrichtung (Sonderzubehör)
 / Programmeur (Pièces en option) / Programador (Piezas opcionales)

REF.NO.	CODE	Q'TY	ヒンメイ	NAME OF PARTS	RM
1	S43249001	1	プログラマークミ	PROGRAMMER ASSY	
1-1	S43250000	1	プログラマーウエフタ	TOP COVER, PROGRAMMER	
1-2	S43251000	1	プログラマーシタフタ	LOWER COVER, PROGRAMMER	
1-3	S43252000	1	キーボードスベサ	SPACER, KEYBOARD	
1-4	S43253000	1	キーボードゴムシート	RUBBER SHEET, KEYBOARD	
1-5	S43254000	1	キーボードシート	KEYBOARD SHEET	
1-6	037301015	4	Vナベタツピン3X10	TAPPING SCREW, PAN V M3X10	
1-7	S43255000	1	LCDカバー	LCD COVER	
1-8	S43256000	1	LCD	LCD	
1-9	S43257000	1	LCDヨウインバーター	INVERTER, LCD	
1-10	037200615	4	Vナベタツピン2X6	TAPPING SCREW, PAN V M2X6	
1-11	S43271000	1	プログラマーマグネットA	MAGNET, A	
1-12	S43272000	1	プログラマーマグネットB	MAGNET, B	
1-13	037300615	6	Vナベタツピン3X6	TAPPING SCREW, PAN V M3X6	
1-14	S43267000	1	プログラマーコード	PROGRAMMER HARNESS	
1-15	S43268000	1	インバーターハーネス	INVERTER HARNESS	
1-16	S43270000	1	コードブツシユKR51	CORD BUSH, KR51	
1-17	S43981000	2	プログラマーシタカバー	LOWER COVER, PROGRAMMER	
1-18	S43259001	1	プログラマキバンクミ	PROGRAMMER PCB ASSY	
1-19	S43269000	1	PROMプログラマクミ	PROM PROGRAMMER ASSY	
1-20	S40621000	1	"オプション部品" EMIコアESD-SR-15	"OPTION PARTS" EMI CORE, ESD-SR-15	
1-21	149809000	1	タイラツプル	BEAD BAND, L = 200	

151-V11-942

X. ワンタッチ押エ装置関係 (オプション部品) / One-touch work clamp (Option parts)
 / One-Touch-Stoffhalterheber (Sonderzubehör) / Pinceur à simple touche (Pièces en option)
 / Prensor de un toque (Piezas opcionales)

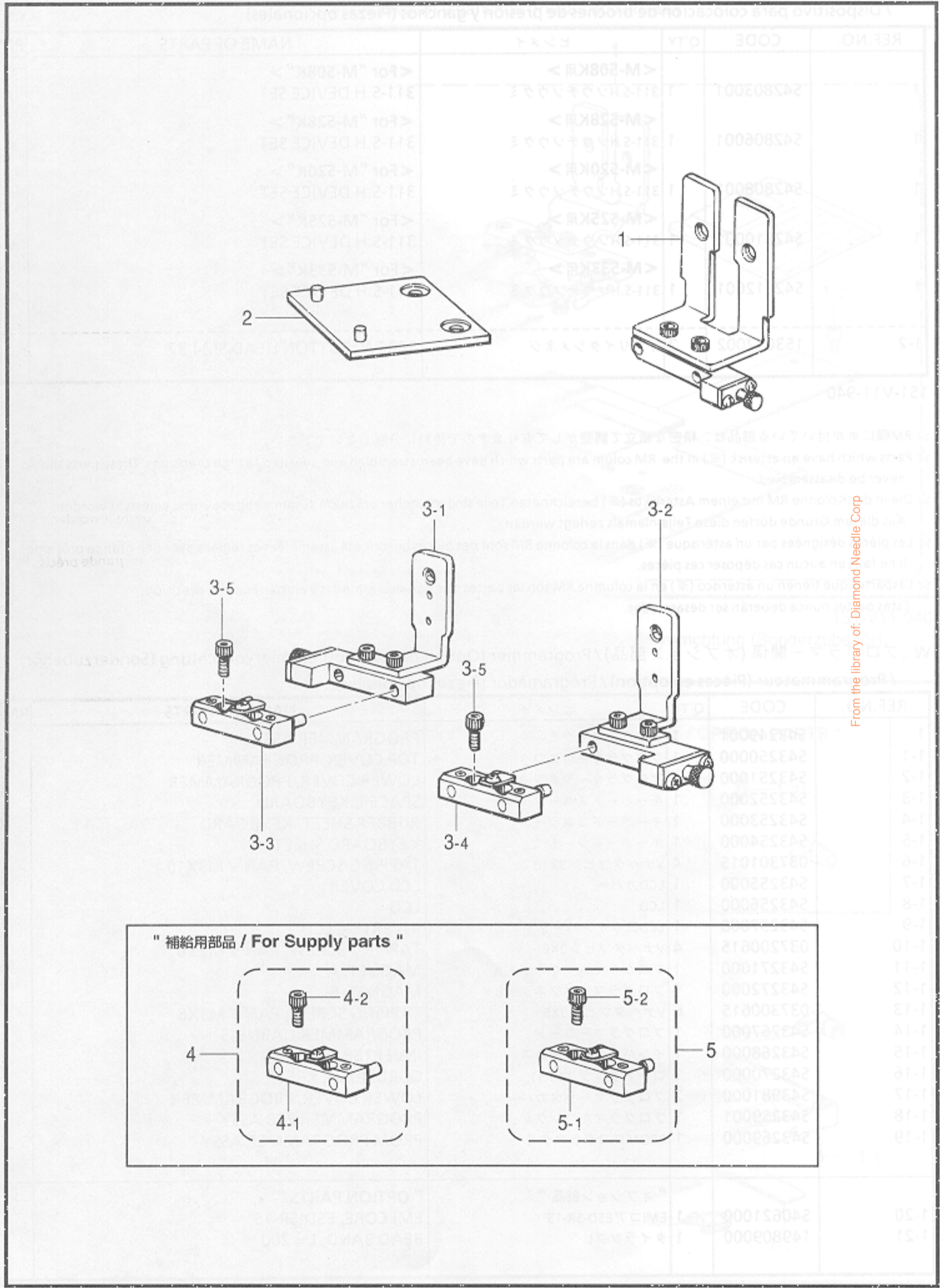

From the library of: Diamond Needle Corp

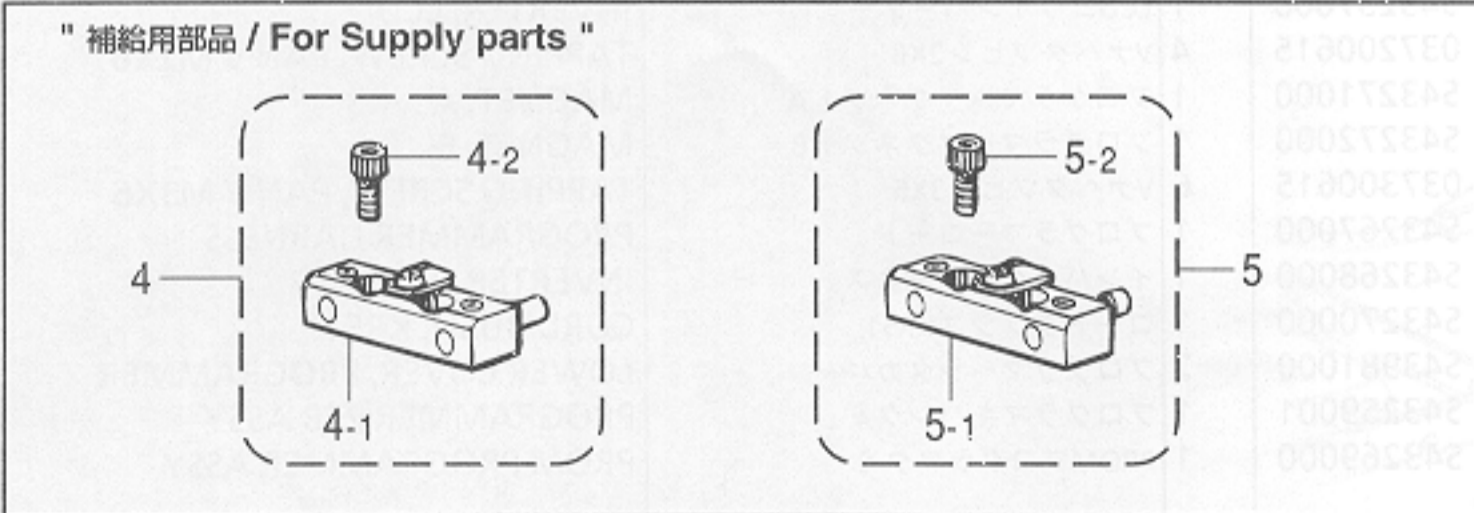

Y. 中押工反転装置関係 (オプション部品) / Inner clamping device (Option parts)

/ Innere Feststellvorrichtung (Sonderzubehör) / Dispositif de griffe intérieure (Pièces en option)

/ Dispositivo prensor interior (Piezas opcionales)

REF.NO.	CODE	Q'TY	ヒンメイ	NAME OF PARTS	RM
1	S44793009	1	ネームツケハンテンソウチセット	INNER CLAMPING DEVICE SET	
1-1	S12633209	1	オサエクランクLAクミ	WORK CLAMP CRANK ASSY, LA	
1-1-1	S12634009	1	オサエクランクホルダA	WORK CLAMP CRANK HOLDER, A	
1-1-2	S12635009	1	オサエクランクホルダB	WORK CLAMP CRANK HOLDER, B	
1-1-3	S12636001	1	オサエクランクホルダC	WORK CLAMP CRANK HOLDER, C	
1-1-4	S12641009	1	クランクホルダカンザ	WASHER, CRNK HOLDER	
1-1-5	018681232	2	アナボルト437-40X12	BOLT, SOCKET SM4.37-40X12	
1-1-6	S12638009	1	ハンテンシリンダダイ	REVERSE CYLINDER BRACKET	
1-1-7	018301236	2	アナボルト3X12	BOLT, SOCKET M3X12	
1-1-8	018301036	2	アナボルト3X10	BOLT, SOCKET M3X10	
1-1-9	S05665001	1	オサエクランクLA	WORK CLAMP CRANK, LA	
1-1-10	154235001	1	ハンテングヤ	REVERSE GEAR	
1-1-11	154236001	1	ハンテンラツク	REVERSE RACK	
1-1-12	145087001	1	ハンテングヤザガネ	WASHER	
1-1-13	149831101	1	アタマツキトメネジ3.18	SET SCREW, SM3.18	
1-1-14	154237001	1	オサエイタホルダL	WORK CLAMP PLATE HOLDER, L	
1-1-15	025350132	1	ヒラザガネシヨウ	WASHER, PLAIN S 3.5	
1-1-16	100242003	1	シメネジ3.57	SCREW, SM3.57	
1-1-17	S12637009	1	ハンテンロツド	REVERSE ROD	
1-1-18	S12639001	1	ハンテンシリンダ	REVERSE CYLINDER	
1-1-19	S12642009	2	アナボルト3X35	BOLT, SOCKET M3X35	
1-1-20	S12640009	1	ハンテングツギテ	JOINT	
1-1-21	018300836	1	アナボルト3X8	BOLT, SOCKET M3X8	
1-1-22	018300836	1	アナボルト3X8	BOLT, SOCKET M3X8	
1-1-23	017501216	1	ボルト5X12	BOLT, M5X12	
1-1-24	021500216	1	2シユナツト5	NUT, 2 M5	
1-1-25	S18415101	2	ハーフユニオンQ4M5	HALF UNION, Q4M5	
1-2	S12643001	1	ソトオサエアシ312-1	OUTER WORK CLAMP, 312-1	
1-3	117291002	2	サラネジ3.18	SCREW, FLAT SM3.18	
1-4	154252001	1	イチギメイタL	POSITIONING PLATE, L	
1-5	154253001	1	イチギメイタR	POSITIONING PLATE, R	
1-6	062670512	4	ナベコ357-40X5	SCREW, PAN SM3.57-40X5	
1-7	025350332	4	ヒラザガネダイ3.5	WASHER, PLAIN L 3.5	
1-8	028350242	4	バネザガネ2-3.5	WASHER, SPRING 2-3.5	
1-9	154256101	1	オサエイタブランクA	WORK CLAMP PLATE BLANK, A	
1-10	S12645001	1	オクリイタブランク312-1	FEED PLATE BLANK, 312-1	
1-11	S44745009	1	ハンテンバルブ3クミ	INNER CLAMP VALVE ASSY, 3	
1-11-1	S31570209	1	バルブトリツケイタ4-5H	VALVE SETTING PLATE, 4-5H	
1-11-2	S44748001	1	エアマニホルド3	AIR MANIFOLD, 3	
1-11-3	062302505	2	ナベコ3X25	SCREW, PAN M3X25	
1-11-4	028030242	2	バネザガネ2-3	WASHER, SPRING 2-3	
1-11-5	025030232	2	ヒラザガネチユウ3	WASHER, PLAIN M 3	
1-11-6	S43683001	1	デンジバルブ	SOLENOID VALVE	
1-11-7	S43696000	1	バルブハーネスX1	VALVE HARNESS, X1	
1-11-7-1	S44746000	1	ツイカバルブハーネス	VALVE HARNESS	
1-11-7-2	S44750000	1	ツイカバルブハーネス24V	VALVE HARNESS, 24V	
1-11-8	S18415101	2	ハーフユニオンQ4M5	HALF UNION, Q4M5	
1-11-9	S12647001	1	エアレギュレータ	AIR REGULATOR	
1-11-10	S29704000	2	コンパクトエルボ4-1/8	ELBOW, 4-1/8	
1-11-11	062404005	2	ナベコ4X40	SCREW, PAN M4X40	
1-12	340400001	2	ユニタイバンド	BEAD BAND	
1-13	S03803000	2	ナイロンチューブ	AIR TUBE, 4 L = 1300	
1-14	S28741000	1	エアーチューブ	AIR TUBE, 4 L = 300	
1-15	021300106	2	1シユナツト3	NUT, 1 M3	
2	S13099001	1	“ 補給用部品 ” ＜ホック付, ベルト縫い用＞ ハリイタH	“ For Supply parts ” ＜For Sewing the belt with hook＞ NEEDLE PLATE, H	
3	S13100001	1	オクリバH	FEED DOG, H	
4	S14598001	1	OTオクリイタブランク312	OT FEED PLATE BLANK, 312	

From the library of: Diamond Needle Corp

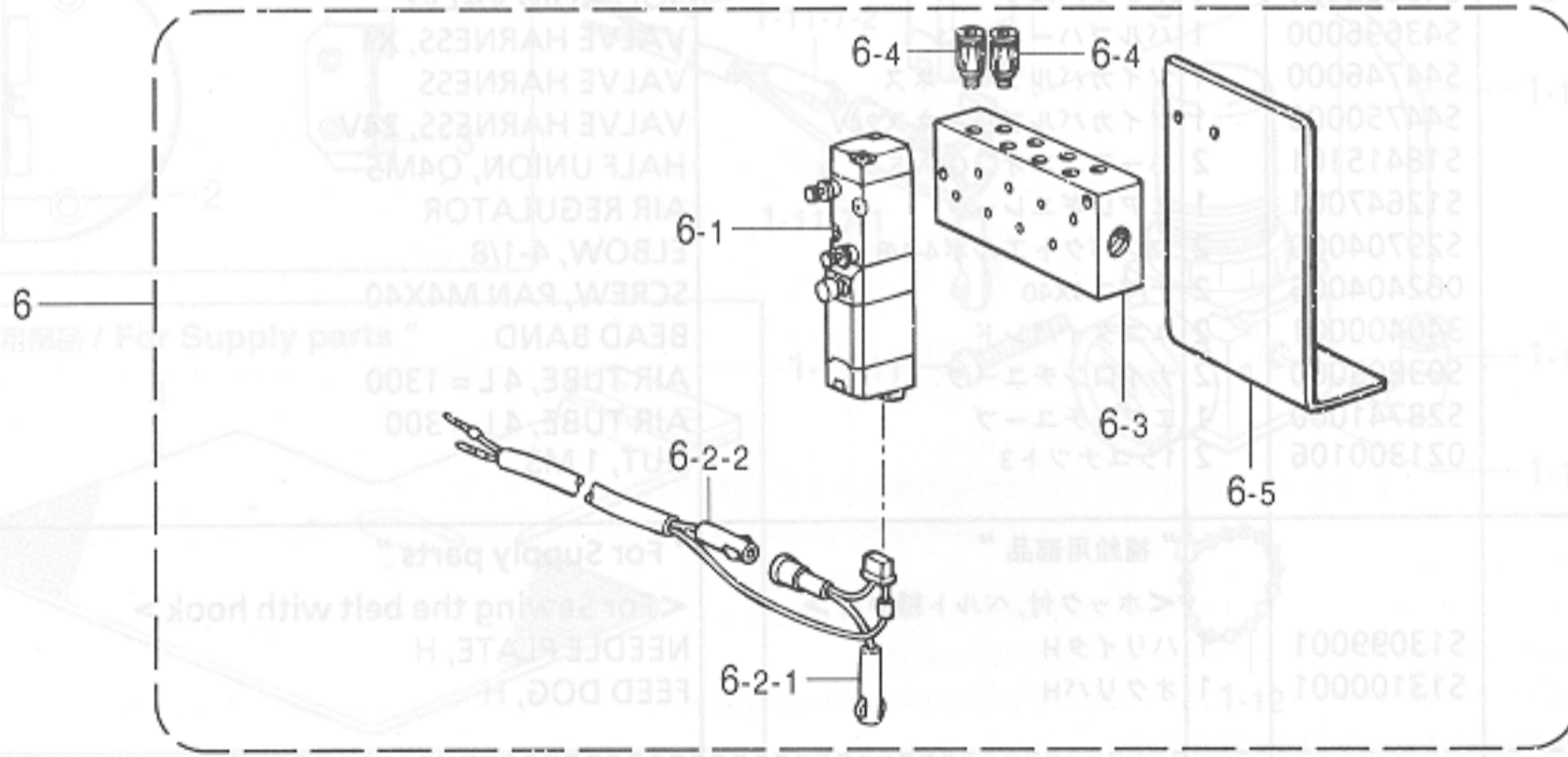
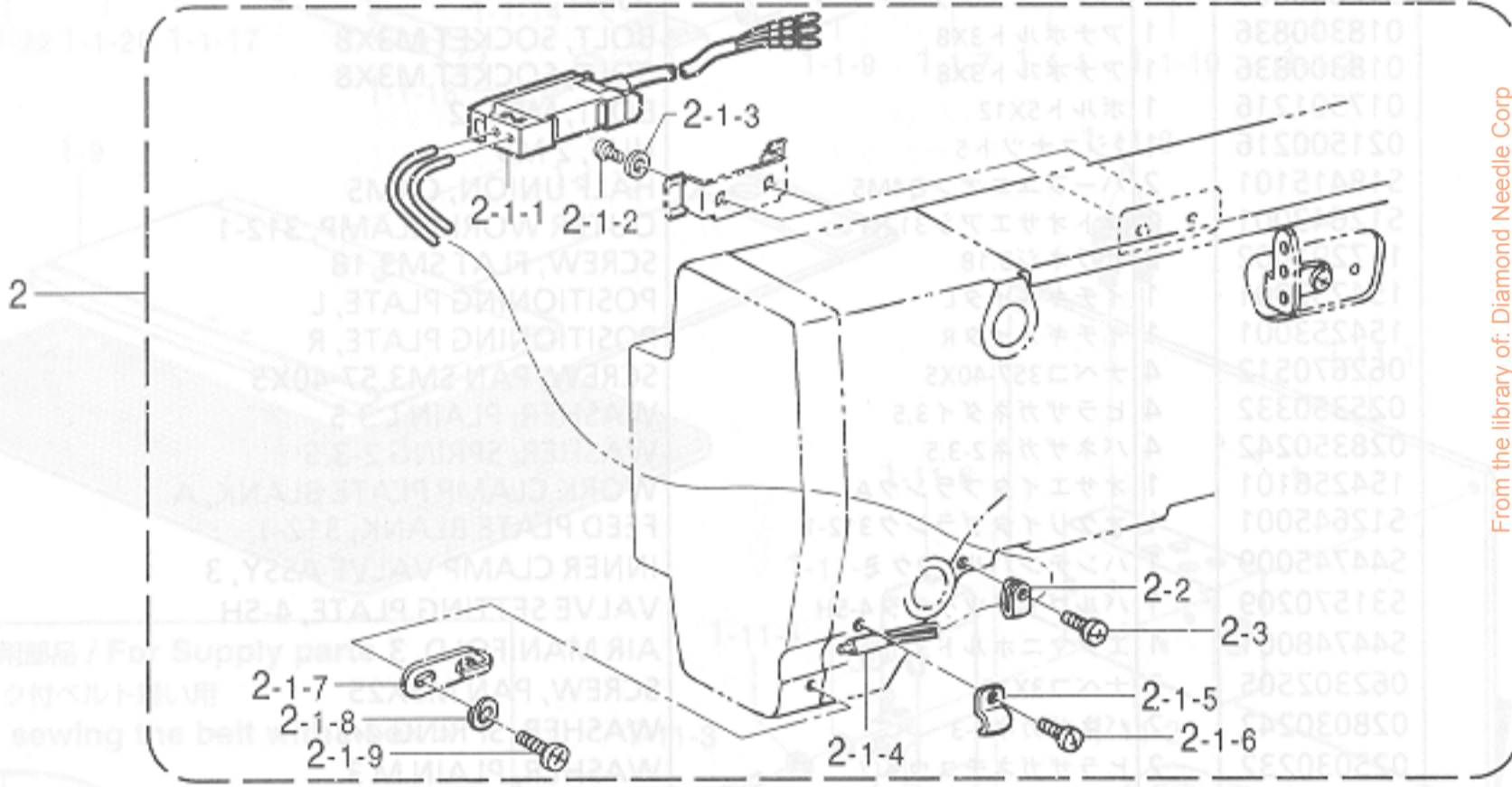
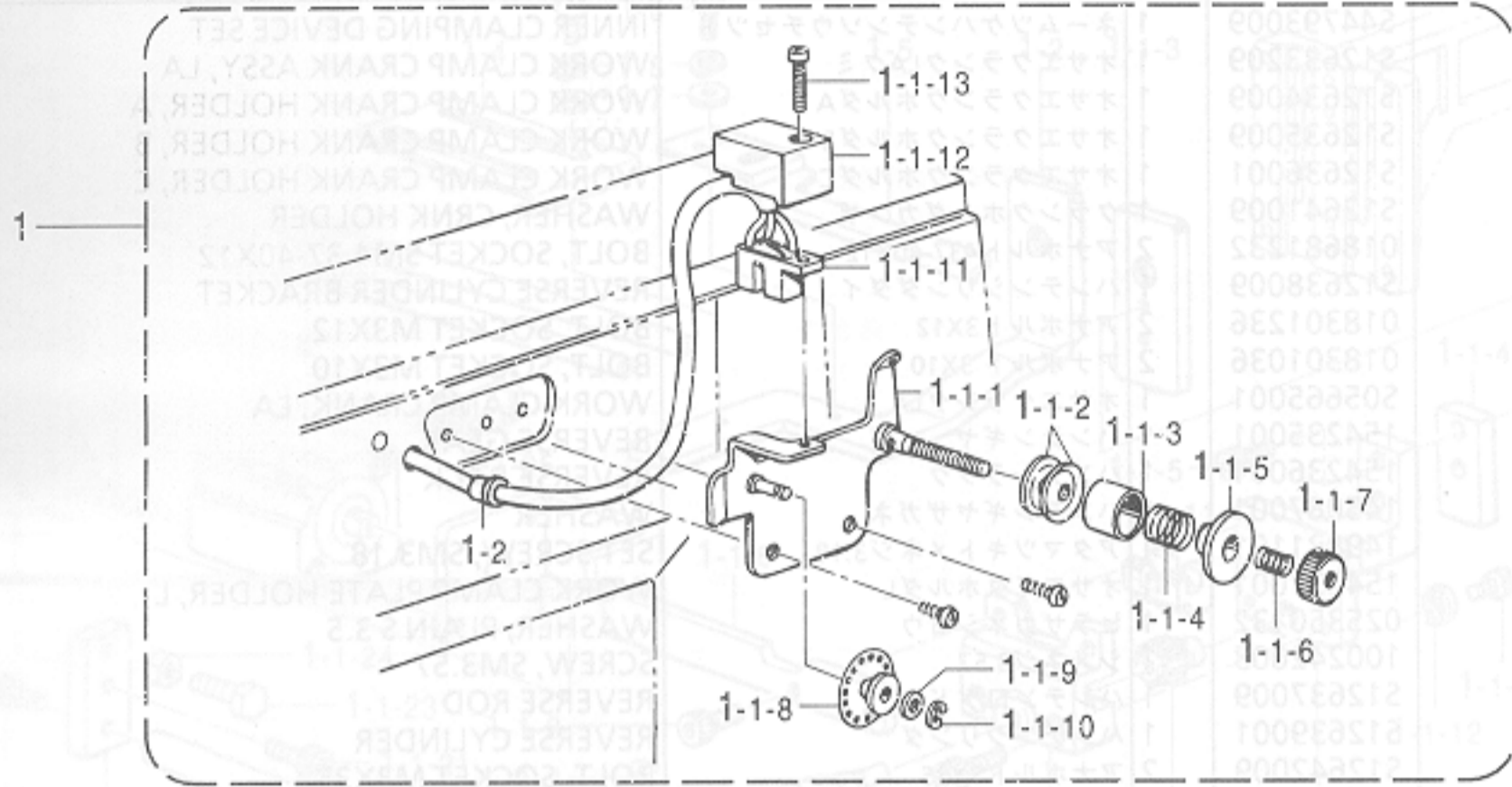

From the library of: Diamond Needle Corp

REF.NO.	CODE	Q'TY	ヒンメイ	NAME OF PARTS	RM
			“糸切れ感知装置”	“ Thread breakage detector ”	
			<ローリー式>	<Rotary-type>	
1	S43833109	1	イトキレカンチソウチセットR	TR. BREAKAGE DETECTOR SET, R	
1-1	S43834109	1	ローリーイトキレカンチクミ	TR. BREAKAGE DETECTOR ASSY, R	
1-1-1	S18032001	1	イトキレカンチブラケットクミ	DETECTOR BRACKET ASSY	
1-1-2	144504001	2	イトアンナイサラ	DISC, THREAD GUIDE	
1-1-3	146206009	1	イトアンナイサラオサエ	DISC PRESSER, THREAD GUIDE	
1-1-4	146058001	1	プレテンションバネ	PRE-TENSION SPRING	
1-1-5	146059001	1	プレテンションナット	PRE-TENSION NUT	
1-1-6	146060000	1	ナットオシバネ	SPRING	
1-1-7	155510001	1	イトチヨウシナット	TENSION NUT	
1-1-8	157255100	1	プーリーA	PULLEY, A	
1-1-9	025030135	1	ヒラザガネシヨウ3	WASHER, PLAIN S 3	
1-1-10	048020342	1	トメワE2	RETAINING RING, E2	
1-1-11	S43835100	1	イトキレフオートセンサークミ	SENSOR ASSY	
1-1-12	S18037009	1	センサーカバー	SENSOR COVER	
1-1-13	062301616	1	ナベコM3X16	SCREW, PAN M3X16	
1-2	146080000	1	コードブシュ	CORD BUSH	
			<ビームセンサー式>	<Beam-type>	
2	S43836201	1	イトキレカンチソウチセットF	TR. BREAKAGE DETECTOR SET, F	
2-1	S43977101	1	イトキレカンチFクミ	TR. BREAKAGE DETECTOR ASSY, F	
2-1-1	S43279100	1	アンプユニット	AMPLIFIER UNIT	
2-1-2	062300612	2	ナベコ3X6	SCREW, PAN M3X6	
2-1-3	025030232	2	ヒラザガネチユウ3	WASHER, PLAIN M 3	
2-1-4	S29468100	1	ファイバユニットN	FIBER UNIT, N	
2-1-5	S11884001	1	センサートリツケイタ	SENSOR SETTING PLATE	
2-1-6	062300612	1	ナベコ3X6	SCREW, PAN M3X6	
2-1-7	S02617001	1	メンタイトアンナイ	THREAD GUIDE, FACE PLATE	
2-1-8	028350242	1	バネザガネ2-3.5	WASHER, SPRING 2-3.5	
2-1-9	060670612	1	バインド357-40X6	SCREW, BIND SM3.57-40X6	
2-2	625010000	1	ナイロンクランプNK-2N	CORD HOLDER, NK-2N	
2-3	060670612	1	バインド357-40X6	SCREW, BIND SM3.57-40X6	
			<追加バルブセット>	<Addition valve set>	
6	S43847101	1	デンジバルブOP4クミ	SOLENOID VALVE ASSY, OP4	
6-1	S43683001	1	デンジバルブ	SOLENOID VALVE	
6-2	S43696000	1	バルブハーネスX1	VALVE HARNESS, X1	
6-2-1	S44746000	1	ツイカバルブハーネス	VALVE HARNESS	
6-2-2	S44750000	1	ツイカバルブハーネス24V	VALVE HARNESS, 24V	
6-3	S44749001	1	エアマニホールド4	AIR MANIFOLD, 4	
6-4	S18415101	2	ハーフユニオンQ4M5	HALF UNION, Q4M5	
6-5	S31554009	1	バルブトリツケイタ4-5	SETTING PLATE, 4-5 VALVE	

From the library of: Diamond Needle Corp

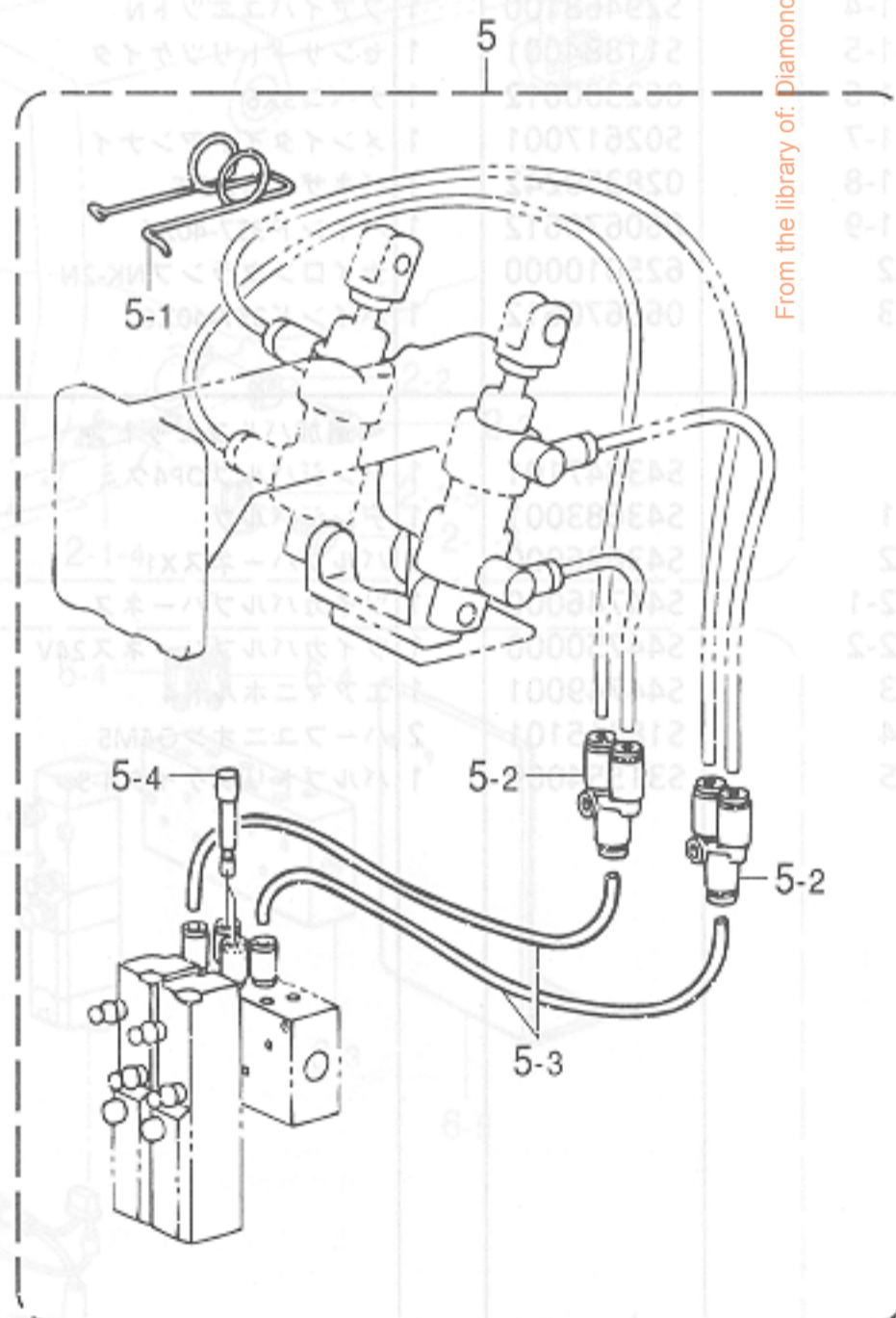
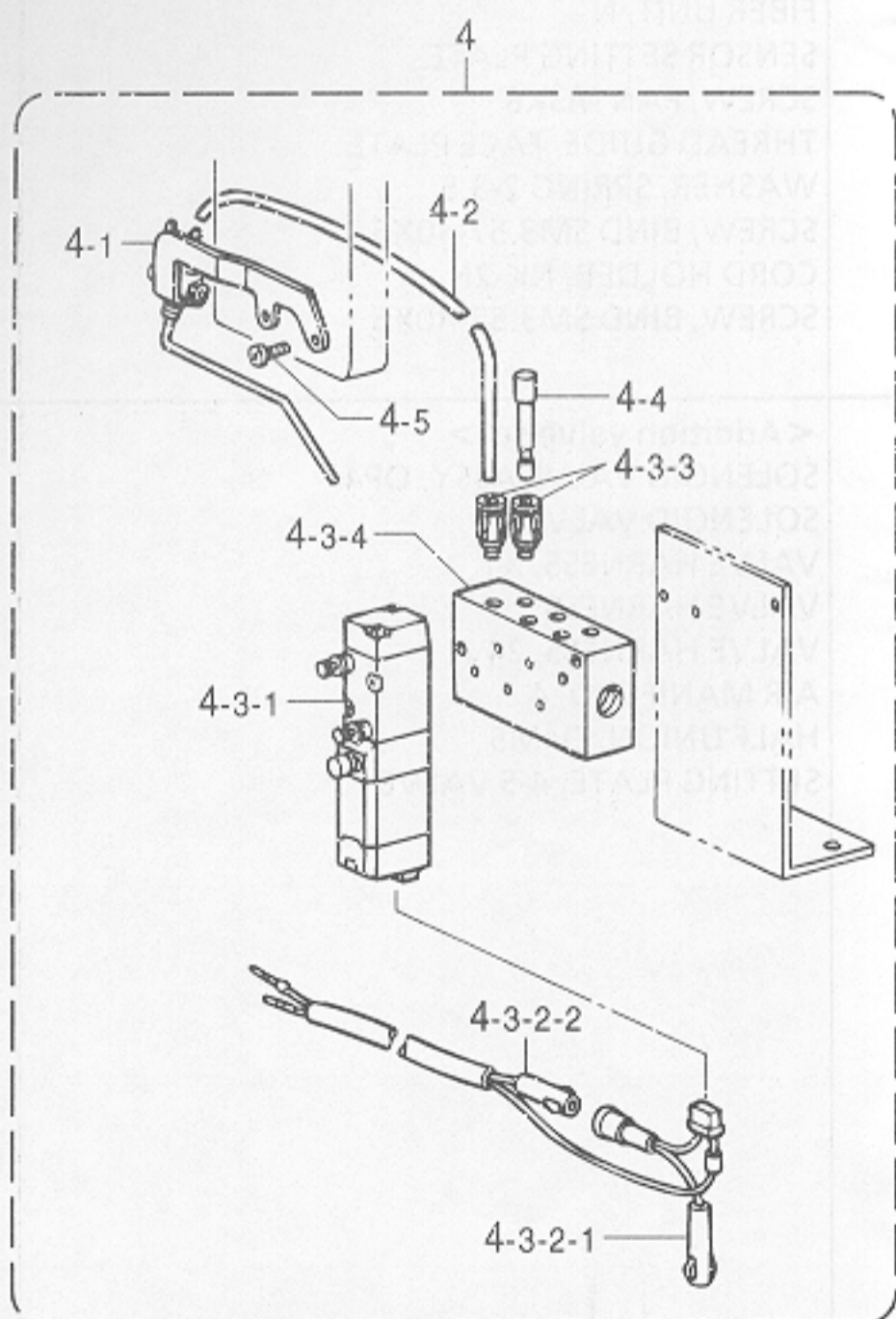
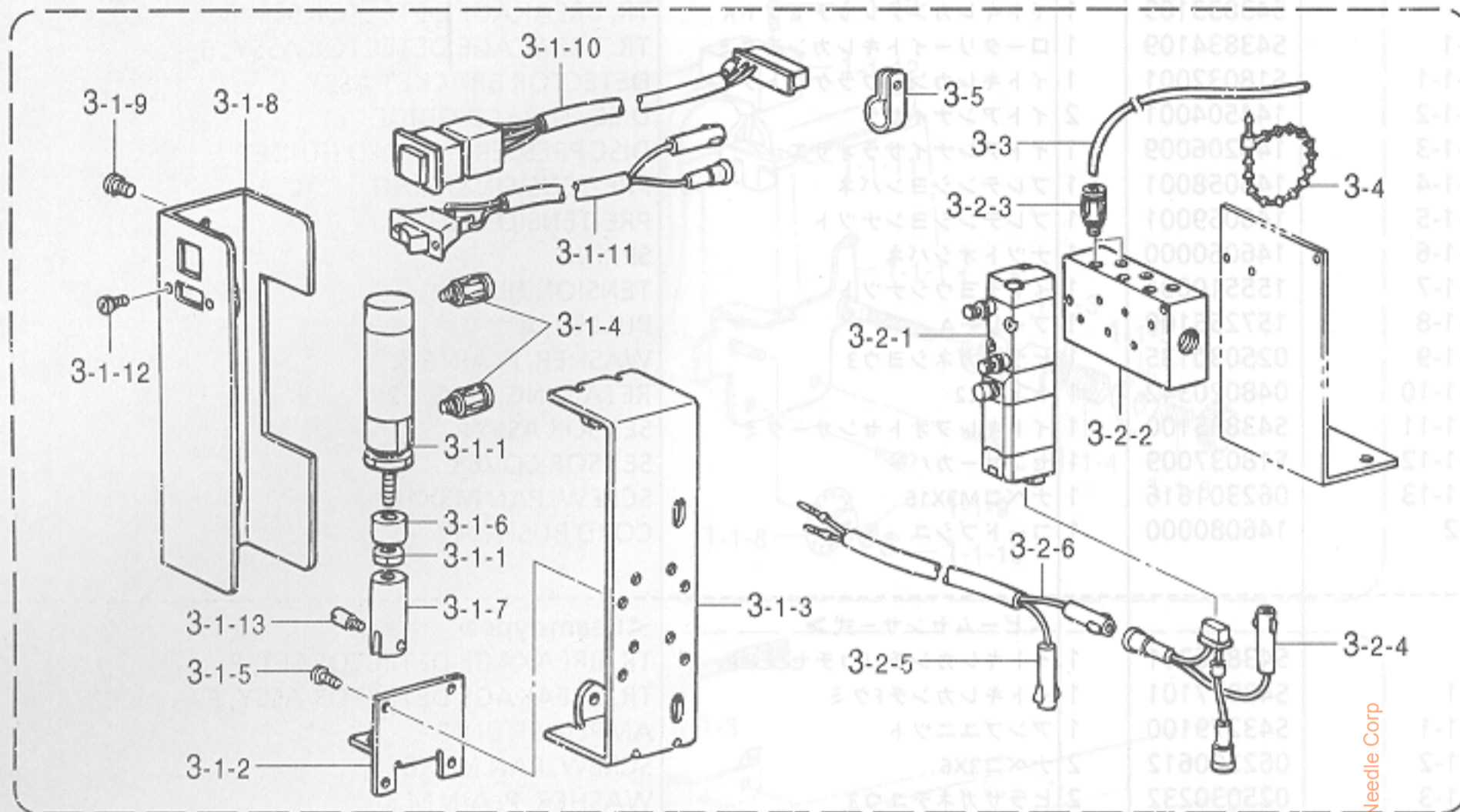

From the library of: Diamond Needle Corp

AA2 . 補助装置関係 (オプション部品) / Auxiliary device (Option parts) / Hilfsvorrichtung (Sonderzubehör)
 / Dispositif auxiliaire (Pièces en option) / Dispositivo auxiliar (Piezas opcionales)

REF.NO.	CODE	Q'TY	ヒンメイ	NAME OF PARTS	RM
			<エアー式ワイパー装置>	<Thread wiper set : Pneumatic type>	
3	S43841009	1	エアーワイパーソウチクミ	TR. WIPER SET, PNEUMATIC TYPE	
3-1	S43842009	1	エアーワイパークミ	TR. WIPER ASSY, PNEUMATIC TYPE	
3-1-1	S17942000	1	エアーシリンダ	AIR CYLINDER	
3-1-2	S31777001	1	シリンダトリツケイタ	CYLINDER SUPPORT PLATE	
3-1-3	S10214109	1	ソレノイドトリツケイタ	SETTING PLATE, SOLENOID	
3-1-4	S18415101	2	ハーフユニオンQ4M5	HALF UNION, Q4M5	
3-1-5	062670612	4	ナベコ357-40X6	SCREW, PAN SM3.57-40X6	
3-1-6	S31778000	1	シリンダーストツバ	STOPPER, CYLINDER	
3-1-7	S31779001	1	シリンダーツギテ	JOINT, CYLINDER	
3-1-8	S31776109	1	シリンダークカバー	CYLINDER COVER	
3-1-9	062680512	2	ナベコ437-40X5	SCREW, PAN SM4.37-40X5	
3-1-10	S43203000	1	EMスイッチクミ	EM-SWITCH ASSY	
3-1-11-1	S43843009	1	イトハライスイッチクミ	THREAD WIPER SWITCH ASSY	
3-1-12	062300612	2	ナベコ3X6	SCREW, PAN M3X6	
3-1-13	S02680001	1	プランジャピン	PLUNGER PIN	
3-2	S43844001	1	AWデンジバルブ3クミ	AW-SOLENOID VALVE ASSY, 3	
3-2-1	S43683001	1	デンジバルブ	SOLENOID VALVE	
3-2-2	S44748001	1	エアマニホールド3	AIR MANIFOLD, 3	
3-2-3	S18415101	2	ハーフユニオンQ4M5	HALF UNION, Q4M5	
3-2-4	S44759000	1	AWバルブハーネスA	AW-VALVE HARNESS, A	
3-2-5	S44760000	1	AWバルブハーネスB	AW-VALVE HARNESS, B	
3-2-6	S44750000	1	ツイカバルブハーネス24V	VALVE HARNESS, 24V	
3-3	S15031008	2	エアーチューブ	AIR TUBE, 4 L = 1900	
3-4	340400001	7	ユニタイバンド	BEAD BAND	
3-5	149287000	4	ナイロンクランプ	CORD HOLDER, 7N	
			<ニードルクーラー装置>	<Needle cooler set>	
4	S43846009	1	ニードルクーラーソウチセット	NEEDLE COOLER SET	
4-1	S18027101	1	ニードルブロワー	NEEDLE BLOWER	
4-2	S15031008	1	エアーチューブ	AIR TUBE, 4 L = 1900	
4-3	S43839008	1	デンジバルブOP3クミ	SOLENOID VALVE ASSY, OP3	
4-3-1	S43683001	1	デンジバルブ	SOLENOID VALVE	
4-3-2	S43696000	1	バルブハーネスX1	VALVE HARNESS, X1	
4-3-2-1	S44746000	1	ツイカバルブハーネス	VALVE HARNESS	
4-3-2-2	S44750000	1	ツイカバルブハーネス24V	VALVE HARNESS, 24V	
4-3-3	S44748001	1	エアマニホールド3	AIR MANIFOLD, 3	
4-3-4	S18415101	2	ハーフユニオンQ4M5	HALF UNION, Q4M5	
4-4	S04897000	1	プラグ4	PLUG, 4	
4-5	062670812	2	ナベコ3.57-40X8	SCREW, PAN SM3.57-40X8	
			<ソフト押エセット>	<Soft work clamp set>	
5	S43979001	1	ソフトオサエセット	SOFT WORK CLAMP SET	
5-1	S43980001	1	ソフトオサエバネ	SPRING	
5-2	S12104000	2	ユニオンワイ4	UNION, Y4	
5-3	S08140000	2	エアーホースS-C	AIR TUBE, 4 L = 200	
5-4	S04897000	2	プラグ4	PLUG, 4	

From the library of: Diamond Needle Corp

AA3. 補助装置関係 (オプション部品) / Auxiliary device (Option parts) / Hilfsvorrichtung (Sonderzubehör)
 / Dispositif auxiliaire (Pièces en option) / Dispositivo auxiliar (Piezas opcionales)

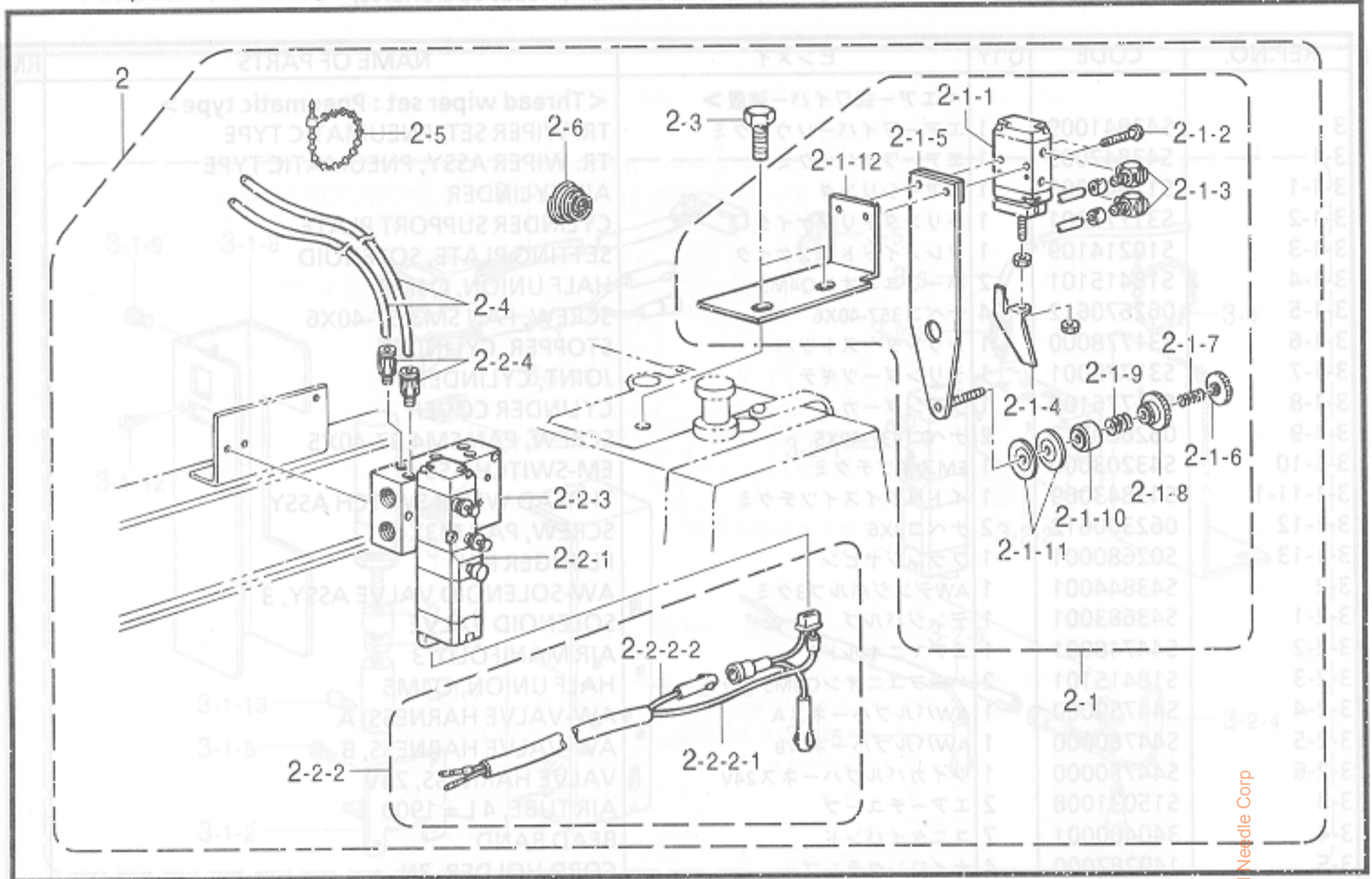

151-V11-944

AB. ワイドパーフェクト装置関係 (オプション部品) / Wide perfect device (Option parts)
 / Wide-perfect-Vorrichtung (Sonderzubehör) / Dispositifs de perfection large (Pièces en option)
 / Dispositivo de ancho perfecto (Piezas opcionales)

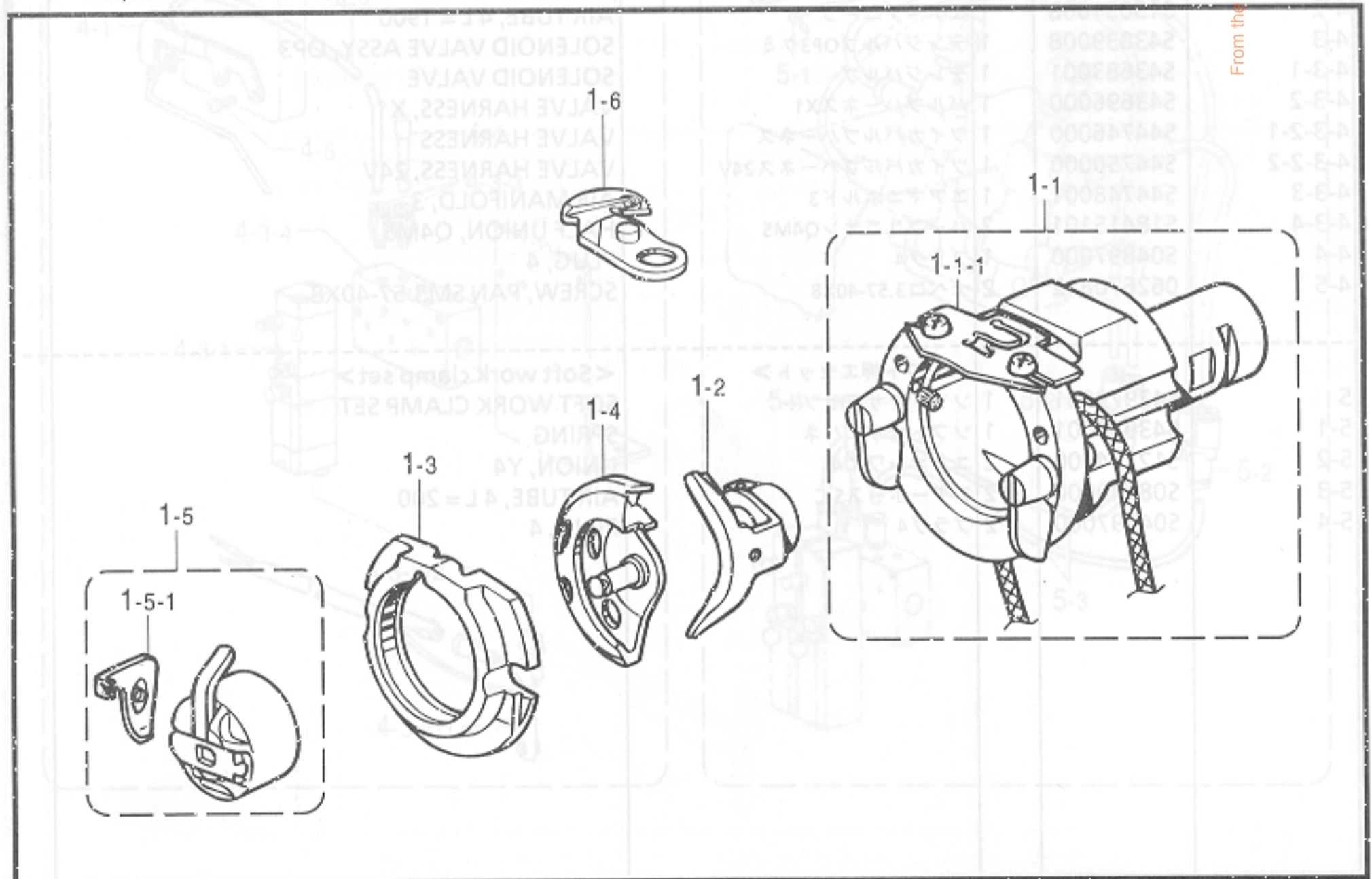

From the library of: Diamond Needle Corp

151-V11-946

AA3. 補助装置関係 (オプション部品) / Auxiliary device (Option parts) / Hilfsvorrichtung (Sonderzubehör)
 / Dispositif auxiliaire (Pièces en option) / Dispositivo auxiliar (Piezas opcionales)

REF.NO.	CODE	Q'TY	ヒンメイ	NAME OF PARTS	RM
			2段糸調子装置<>	<2-step tension device>	
2	S43837001	1	2ダンテソウチセット1	2-STEP THREAD TENSION DEVICE SET, 1	
2-1	S43838001	1	2ダンテシヨクミ	2-STEP THREAD TENSION ASSY	
2-1-1	S34706000	1	エアシリンダ10X10	AIR CYLINDER, 10X10	
2-1-2	018302032	2	アナボルト3X20	BOLT, SOCKET M3X20	
2-1-3	S12150000	2	ホースエルボM-5HL-4	TUBE ELBOW, M-5HL-4	
2-1-4	S34533001	1	サラツリツメ	COUNTERSINK CLAW	
2-1-5	S34534001	1	サブテンションダイクミ	SUB TENSION BRACKET ASSY	
2-1-6	155510001	1	イトチヨウシナツト	TENSION NUT	
2-1-7	146060000	1	ナツトオシバネ	SPRING	
2-1-8	146059001	1	プレテンションナツト	PRE-TENSION NUT	
2-1-9	146058001	1	プレテンションバネ	PRE-TENSION SPRING	
2-1-10	146206009	1	イトアンナイサラオサエ	DISC PRESSER, THREAD GUIDE	
2-1-11	144504001	2	イトアンナイサラ	DISC, THREAD GUIDE	
2-1-12	S34536001	1	シリンダートリツケイタ	CYLINDER SETTING BRACKET	
2-2	S43839005	1	デンジバルブOP3クミ	SOLENOID VALVE ASSY, OP3	
2-2-1	S43683001	1	デンジバルブ	SOLENOID VALVE	
2-2-2	S43696000	1	バルブハーネスX1	VALVE HARNESS, X1	
2-2-2-1	S44746000	1	ツイカバルブハーネス	VALVE HARNESS	
2-2-2-2	S44750000	1	ツイカバルブハーネス24V	VALVE HARNESS, 24V	
2-2-3	S44748001	1	エアマニホルド3	AIR MANIFOLD, 3	
2-2-4	S18415101	2	ハーフユニオンQ4M5	HALF UNION, Q4M5	
2-3	017821813	2	ボルト7.94X18	BOLT, SM7.94X18	
2-4	S15031008	2	エアチューブ	AIR TUBE, 4 L = 1900	
2-5	340400001	5	ユニタイバンド	BEAD BAND	
2-6	104525001	1	イトチヨウシバネ	SPRING, TENSION	
2-7	149287000	3	ナイロンクランプ	CORD HOLDER, 7N	

151-V11-944

AB. ワイドパーフェクト装置関係 (オプション部品) / Wide perfect device (Option parts)
 / Wide-perfect-Vorrichtung (Sonderzubehör) / Dispositif de perfection large (Pièces en option)
 / Dispositivo de ancho perfecto (Piezas opcionales)

REF.NO.	CODE	Q'TY	ヒンメイ	NAME OF PARTS	RM
1	S44795001	1	300EワイドPセット	WIDE PERFECT STITCH SET, 300E	
1-1	S40837001	1	Z11オオカマタイWPクミ	SHUTTLE RACE BASE ASSY, WP	
1-1-1	S40839001	1	カマイトアンナイWP	SHUTTLE RACE THREAD GUIDE, WP	
1-2	S40840001	1	ドライバーWP	DRIVER, WP	
1-3	S40841101	1	オオカマWP	SHUTTLE RACE BODY, WP	
1-4	S40842991	1	ナカカマWPハコクミ	SHUTTLE HOOK BOX ASSY, WP	
1-5	S40843001	1	ボビンケースクミWP	BOBBIN CASE ASSY, WP	
1-5-1	S40845001	1	ケースチヨウシバネWP	TENSION SPRING, WP	
1-6	S40846001	1	イドウハWPクミ	MOVABLE KNIFE ASSY, WP	
20	S40843002	2	クッション	CUSHION	
21	S40843003	2	ネイル	NAIL	
22	S40843004	1	オイルアッシー	OILER ASSY	
23	S40843005	1	オイルタンク	OIL TANK	
24	S40843006	1	フューズSA	FUSE, SA	
25	S40843007	1	フューズ6A	FUSE, 6A	
26	S40843008	1	ネジドライバー1.9X52	SCREW-DRIVER, 1.9X52	
27	S40843009	1	ネジドライバー3.4X70	SCREW-DRIVER, 3.4X70	
28	S40843010	1	ネジドライバー5.5X190	SCREW-DRIVER, 5.5X190	
29	S40843011	1	レンチCBX7	WRENCH-CBX7	
30	S40843012	1	レンチCBX9	WRENCH-CBX9	

151-V11-946

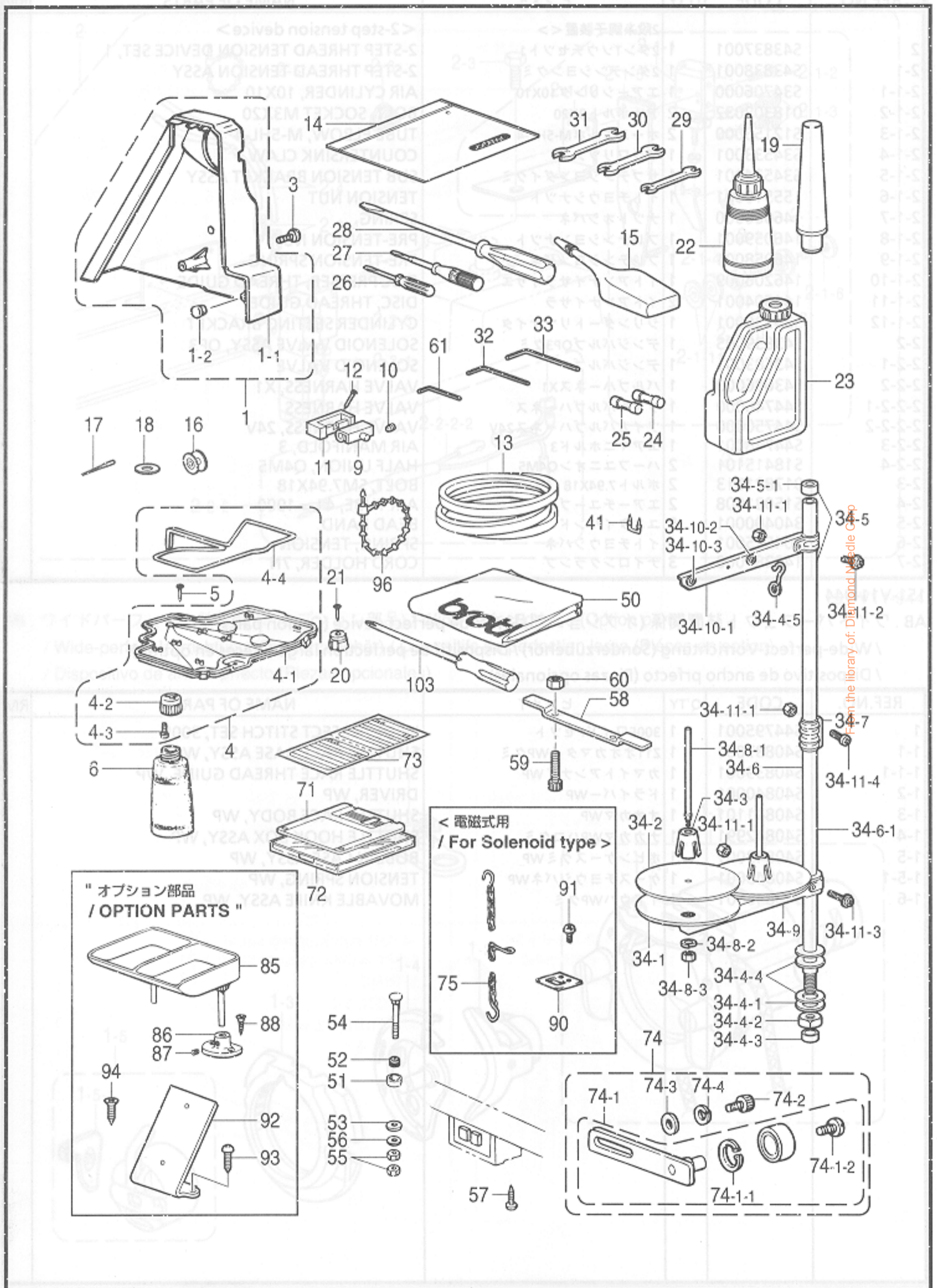

REF.NO.	CODE	Q'TY	ヒンメイ	NAME OF PARTS	RM
1	S42814009	1	ベルトカバー-311クミ	BELT COVER ASSY, 311	
1-1	S42815009	1	ベルトカバー-311	BELT COVER, 311	
1-2	104450109	1	ゴムセン8	RUBBER CAP, 8	
3	062401006	1	ナベコ4X10	SCREW, PAN M4X10	
4	S38039109	1	オイルパンクミ	OIL PAN ASSY	
4-1	S38040109	1	オイルパン	OIL PAN	
4-2	154467001	1	ハイユキヤツブ	DUST OILER	
4-3	037301215	2	Vナベタツピン3X12	TAPPING SCREW, PAN V M3X12	
4-4	S18093100	1	クミヒモ4X4	WICK, 4X4 L = 1100	
5	109714000	5	クギ	NAIL	
6	114486002	1	ポリオイラータイ	OILER	
9	143882001	2	トウブヒンジ	HEAD HINGE	
10	014760622	2	アナトメネジ5.95	SET SCREW, SOCKET SM5.95	
11	143910009	2	トウブヒンジウケゴム	RUBBER CUSHION	
12	109714000	4	クギ	NAIL	
13	S18707149	1	VベルトMシロ	BELT, VM WHITE	
14	122991001	1	フゾクヒンポリフクロ	ACCESSORY BAG	
15	S06706001	1	シリコンオイル	SILICONE OIL	
<311E中厚物, 厚物用>				<For Medium & heavy-weight materials of 311E>	
16	S15665001	3	ボビンLA	<For Heavy-weight materials of 311EL> BOBBIN, LA	
16	S15666001	3	ボビンLB	<For Extra heavy weight-materials of 311E> BOBBIN, LB	
<311E中厚物用>				<For Medium-weight materials of 311E>	
17	107415416	1	ミシンハリDPX5#16クミ	NEEDLE ASSY, DPX5 (#16)	
<311E, 311EL厚物用>				<For Heavy-weight materials of 311E & 311EL>	
17	145646421	1	ミシンハリDPX17#21クミ	NEEDLE ASSY, DPX17 (#21)	
<311E極厚物用>				<For Extra heavy weight-materials of 311E>	
17	145646425	1	ミシンハリDPX17#25クミ	NEEDLE ASSY, DPX17 (#25)	
18	S10208001	1	イドウハカンザ t=0.4	SPACER, MOVABLE KNIFE T = 0.4 t = 0.4	
18	S10208002	1	イドウハカンザ t=0.5	SPACER, MOVABLE KNIFE T = 0.5 t = 0.5	
18	S10208003	1	イドウハカンザ t=0.6	SPACER, MOVABLE KNIFE T = 0.6 t = 0.6	
19	S45724009	1	マクラA	HEAD REST, A	
20	S38043009	2	クツシヨン	CUSHION	
21	109714000	2	クギ	NAIL	
22	114483002	1	ポリオイラークミ	OILER ASSY	
23	154702101	1	オイルタンク	OIL TANK	
24	S08030000	1	Gヒューズ5AFB	FUSE, 5A FB	
25	153242000	1	ヒューズ6A	FUSE, 6A	
26	142443001	1	ネジマワシ1.9X52	SCREW DRIVER, 1.9X52	
27	118837001	1	ネジマワシ3.4X70	SCREW DRIVER, 3.4X70	
28	101572101	1	ネジマワシ5.5X190	SCREW DRIVER, 5.5X190	
29	107779001	1	スパナ6X7	WRENCH, 6X7	
30	100887001	1	スパナ8X9	WRENCH, 8X9	

151-V11-910

- ◎ 付属品の明細は変更することがあります。
- ◎ The details of included accessories are subject to change.
- ◎ Änderungen in der Aufstellung der Mitgelieferten Zubehöre sind vorbehalten.
- ◎ Les détails des accessoires inclus sont sujets à des changements.
- ◎ Los detalles de accesorios incluidos pueden variar.

REF.NO.	CODE	Q'TY	ヒンメイ	NAME OF PARTS
31	107780001	1	スパナ10X12	WRENCH, 10X12
32	142721001	1	6カクボウスパナ3	HEXAGONAL WRENCH, 3
33	118064001	1	6カクボウスパナ4	HEXAGONAL WRENCH, 4
34	S02763302	1	イトタテダイクミ2DR	COTTON STAND ASSY, 2DR
34-1	150180001	2	ウケザラ	SPOOL STAND BASE
34-2	150182000	2	スプールマット	SPOOL MAT
34-3	126863001	2	スプールのクッション	SPOOL CUSHION
34-4	S02777001	1	パイプDネジセットB	PIPE (D) SCREW SET, B
34-4-1	150206002	1	ヒラザガネ16	WASHER, PLAIN 16
34-4-2	S38648001	1	6カクナットU5/8	NUT, U5/8-28
34-4-3	150174000	1	コラムキャップ	COLUMN CAP
34-4-4	S01005000	2	イトタテゴム	RUBBER WASHER
34-4-5	S02747101	1	イトカケバネ	SPRING
34-5	S40640001	1	コラムパイプキャップツキ	COLUMN PIPE WITH CAP
34-5-1	150174000	1	コラムキャップ	COLUMN CAP
34-6	156112003	1	コラムパイプD	COLUMN PIPE, D
34-6-1	150207001	1	コラムパイプネジツキ	COLUMN PIPE W/SCREW
34-6-2	150206000	1	ヒラザガネ16	WASHER, PLAIN 16
34-7	150173003	1	コラムジョイント	COLUMN JOINT
34-8	S21798001	2	スプールネジセット	SPOOL SCREW SET
34-8-1	150179002	2	スプールジクB	SPOOL SHAFT, B
34-8-2	028050246	2	バネザガネ2-5	WASHER, SPRING 2-5
34-8-3	021500106	2	1シユナット5	NUT, 1 M5
34-9	S02778002	1	スプールホルダー2	SPOOL HOLDER, 2
34-10	S02786002	1	スレツドハンガークミ2	THREAD HANGER ASSY, 2
34-10-1	S02787002	1	スレツドハンガー2	THREAD HANGER, 2
34-10-2	150183000	2	イトカケハンガーダイ	THREAD HANGER BASE
34-10-3	142990001	2	スレツドブツシュ	THREAD BUSH
34-11	S40641001	1	スプールジクネジセットA	SPOOL SCREW SET, A
34-11-1	021500106	4	1シユナット5	NUT, 1 M5
34-11-2	S37038001	1	ナベコヒラザ5X14	SCREW, PAN (S/P WASHER) M5X14
34-11-3	S37037001	1	ナベコヒラザ5X32	SCREW, PAN (S/P WASHER) M5X32
34-11-4	062501406	2	ナベコ5X14	SCREW, PAN M5X14
41	200190001	5	ステツブル	STAPLE
50	144226001	1	トウブカバー	HEAD COVER
51	146256001	4	<コントロールボックス取付用> クッションカナグ	<For setting the control box> CUSHION COLLAR
52	146255000	4	クッション	CUSHION
53	S00617000	4	ボウシンゴムカラー	RUBBER COLLAR
54	133740006	4	カクネボルト6X70	BOLT, M6X70
55	021060106	8	1シユナット6	NUT, 1 M6
56	025060336	4	ヒラザガネダイ6	WASHER, PLAIN L 6
57	032461606	2	<電源スイッチ取付用> + マルモクネジ4.5X16	<For setting the power switch> WOOD SCREW, ROUND M4.5X16
58	S42882001	1	ヒンジオサエ	HINGE PRESSER
59	018405032	2	アナボルト4X50	BOLT, SOCKET M4X50
60	021400102	2	ナット1シユ4	NUT, 1 M4
61	S07783001	1	6カクボウスパナ1.5	HEXAGONAL WRENCH, 1.5

From the library of: Diamond Needle Corp

151-V11-910

◎ 付属品の明細は変更することがあります。

◎ The details of included accessories are subject to change.

◎ Änderungen in der Aufstellung der Mitgelieferten Zubehöre sind vorbehalten.

◎ Les détails des accessoires inclus sont sujets à des changements.

◎ Los detalles de accesorios incluidos pueden variar.

Z. 付属品関係 / Accessories / Zubehör / Accessoires / Accesorios

REF.NO.	CODE	Q'TY	ヒンメイ	NAME OF PARTS	RM
63	018400632	2	アナボルト4X6	BOLT, SOCKET M4X6	
71	S43273000	1	3.5メディア2HD	3.5 MEDIA, 2HD	
72	S09989000	1	フロッピーケース	FLOPPY CASE	
73	S42658000	1	3.5インデックスラベル	INDEX LABEL, 3.5FD	
74	S43832001	1	テンションプーリオオクミ	TENSION PULLEY SET	
74-1	S43676001	1	テンションプーリクミ	TENSION PULLEY ASSY	
74-1-1	048320242	1	トメワアナヨウC32	RETAINING RING, C32	
74-1-2	141860001	1	シメネジ6.35	SCREW, SM6.35	
74-2	018081222	1	アナボルト8X12	BOLT, SOCKET M8X12	
74-3	025080232	1	ヒラザガネチユウ8	WASHER, PLAIN M 8	
74-4	028080242	1	バネザガネ2-8	WASHER, SPRING 2-8	

75	S10472001	1	<BAS-311E電磁式用> クサリクミ	<For Solenoid type of BAS-311E> CHAIN ASSY	
90	S42883001	1	レンカンアンナイタ	CONNECTING ROD GUIDE PLATE	
91	062670612	2	ナベコ357-40X6	SCREW, PAN SM3.57-40X6	

96	340400001	1	<エア-式用> ユニタイバンド	<For Pneumatic type> BEAD BAND	

103	150332001	1	<BAS-311EL用> プラスドライバーNO.2	<For BAS-311EL> SCREW, DRIVER, 2X100	

85	S18641009	1	"オプション部品" ボタンサラフクロイリ	"OPTION PARTS" BUTTON TRAY WITH BAG	
86	153843009	1	ボタンサラアシホルダ	BUTTON CLAMP HOLDER SUPPORT	
87	014760622	1	アナトメネジ5.95	SET SCREW, SOCKET SM5.95	
88	0B1351606	2	+サラモク35X16	WOOD SCREW, FLAT M3.5X16	
92	S42890001	1	プログラマササエ	PROGRAMMER SUPPORT	
93	032422003	2	+マルモクネジ4.1X20	WOOD SCREW, ROUND M4.1X20	
94	0B1351606	2	+サラモク35X16	WOOD SCREW, FLAT M3.5X16	

From the library of Diamond Needle Corp

151-V11-910

◎ 付属品の明細は変更することがあります。

◎ The details of included accessories are subject to change.



◎ Änderungen in der Aufstellung der Mitgelieferten Zubehöre sind vorbehalten.

◎ Les détails des accessoires inclus sont sujets à des changements.

◎ Los detalles de accesorios incluidos pueden variar.

Ga1 . ゲージ部品一覧表 / Gauge parts List / Lehrenliste / Liste des Pièces de cartment
/ Lista d'ePiezas de calibradores

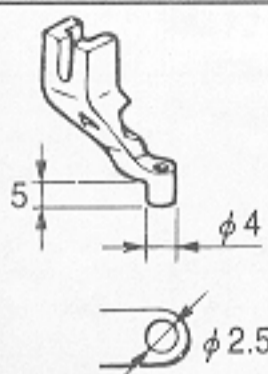
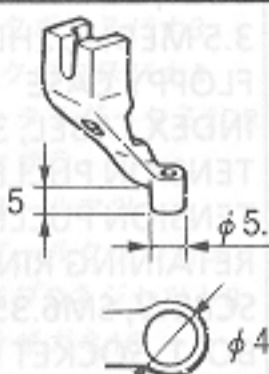
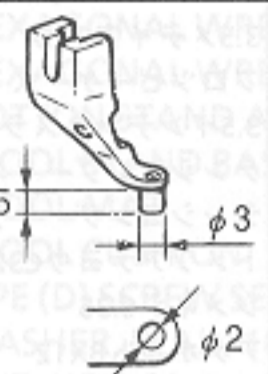
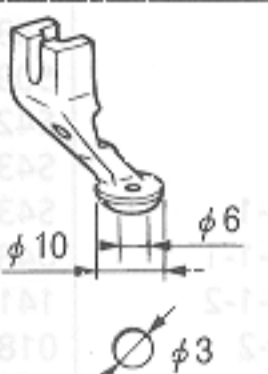
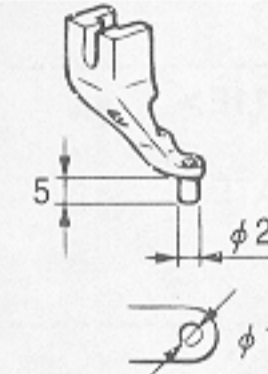
押工足 / Presser foot

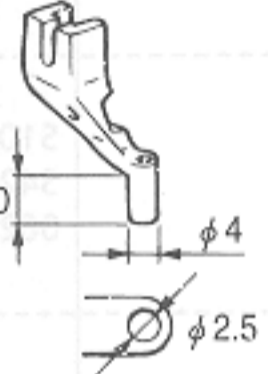
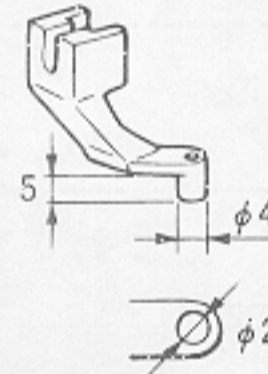
Ref.No.A *	Ref.No.B	Ref.No.C	Ref.No.D
			
Ref.No.E	Ref.No.F	Ref.No.G	Ref.No.J
			
Ref.No.XY			
			

針穴板 / Needle hole plate

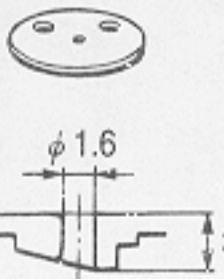
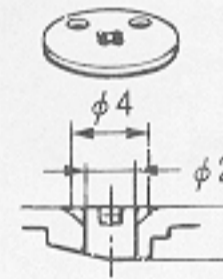
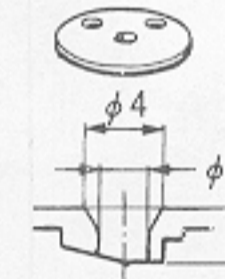
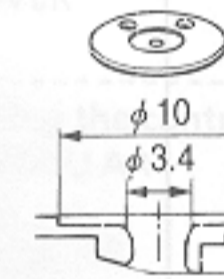
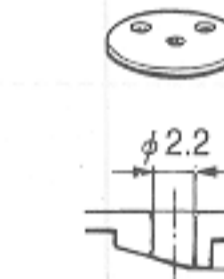
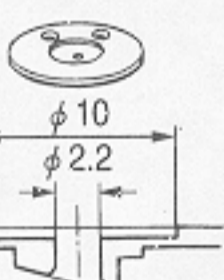
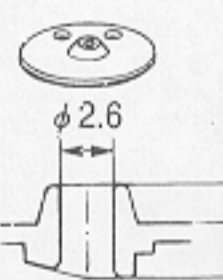
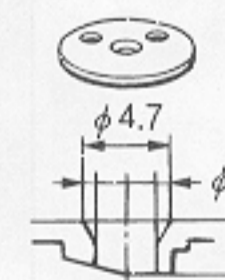
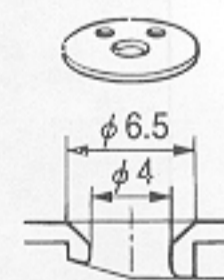
Ref.No.A	Ref.No.D	Ref.No.E *	Ref.No.ED	Ref.No.F *
				
Ref.No.FD	Ref.No.H	Ref.No.L	Ref.No.M *	
				

- ☆ *印の部品は、標準部品です。
- ☆ The * symbol is for Standard parts.
- ☆ Mit dem Zeichen * Standardteile bezeichnet.
- ☆ Le symbol * correspond aux pièces normales.
- ☆ El asterisco * es para piezas normales.

From the library of: Diamond Needle Corp

Ga1 . ゲージ部品一覧表 / Gauge parts List / Lehrenliste / Liste des Pièces de cartment
/ Lista d'ePiezas de calibradores

REF.NO.	CODE	Q'TY	ヒンメイ	NAME OF PARTS	RM
A	S42843001	1	オサエアシA	PRESSER FOOT, A	※
B	S42844001	1	オサエアシB	PRESSER FOOT, B	
C	S42845001	1	オサエアシC	PRESSER FOOT, C	
D	S42846001	1	オサエアシD	PRESSER FOOT, D	
E	S42847001	1	オサエアシE	PRESSER FOOT, E	
F	157237001	1	オサエアシF	PRESSER FOOT, F	
G	158592001	1	オサエアシG	PRESSER FOOT, G	
J	S42848001	1	オサエアシJ	PRESSET FOOT, J	
XY	S42849001	1	<横払イワイパー用> オサエアシXY	<For Horizontal wiper> PRESSER FOOT, XY	
E	S10212101	1	<311E, 311EL厚物用> ハリアナイタE Ø2.6	<For 311E & 311EL "Heavy-weight materials"> NEEDLE HOLE PLATE, E Ø2.6	※
F	S10213001	1	<311E中厚物用> ハリアナイタF Ø2.2	<For 311E "Medium-weight materials"> NEEDLE HOLE PLATE, F Ø2.2	※
	S34348001	1	<311E極厚物用> ハリアナイタM Ø4.0	<For 311E "Extra heavy-weight materials"> NEEDLE HOLE PLATE, M Ø4.0	※
A	S10211001	1	ハリアナイタA Ø1.6	NEEDLE HOLE PLATE, A Ø1.6	
D	S29997001	1	ハリアナイタD Ø2.6	NEEDLE HOLE PLATE, D Ø2.6	
ED	S30925001	1	ハリアナイタED Ø3.4	NEEDLE HOLE PLATE, ED Ø3.4	
FD	S30926001	1	ハリアナイタFD Ø2.2	NEEDLE HOLE PLATE, FD Ø2.2	
H	S30450001	1	ハリアナイタH Ø2.6	NEEDLE HOLE PLATE, H Ø2.6	
L	S25127001	1	ハリアナイタL Ø3.3	NEEDLE HOLE PLATE, L Ø3.3	
			<デニム用> OTオクリイタDE 1.2	<For Denim> OT-FEED PLATE BLANK, DE	
			<一般用> OTオクリイタST 1.2	<For General> OT-FEED PLATE, ST	

151-V11

- ☆ ※印の部品は、標準部品です。
- ☆ The ※ symbol is for Standard parts.
- ☆ Mit dem Zeichen ※ Standardteile bezeichnet.
- ☆ Le symbol ※ correspond aux pièces normales.
- ☆ El asterisco ※ es para piezas normales.

From the library of: Diamond Needle Co.

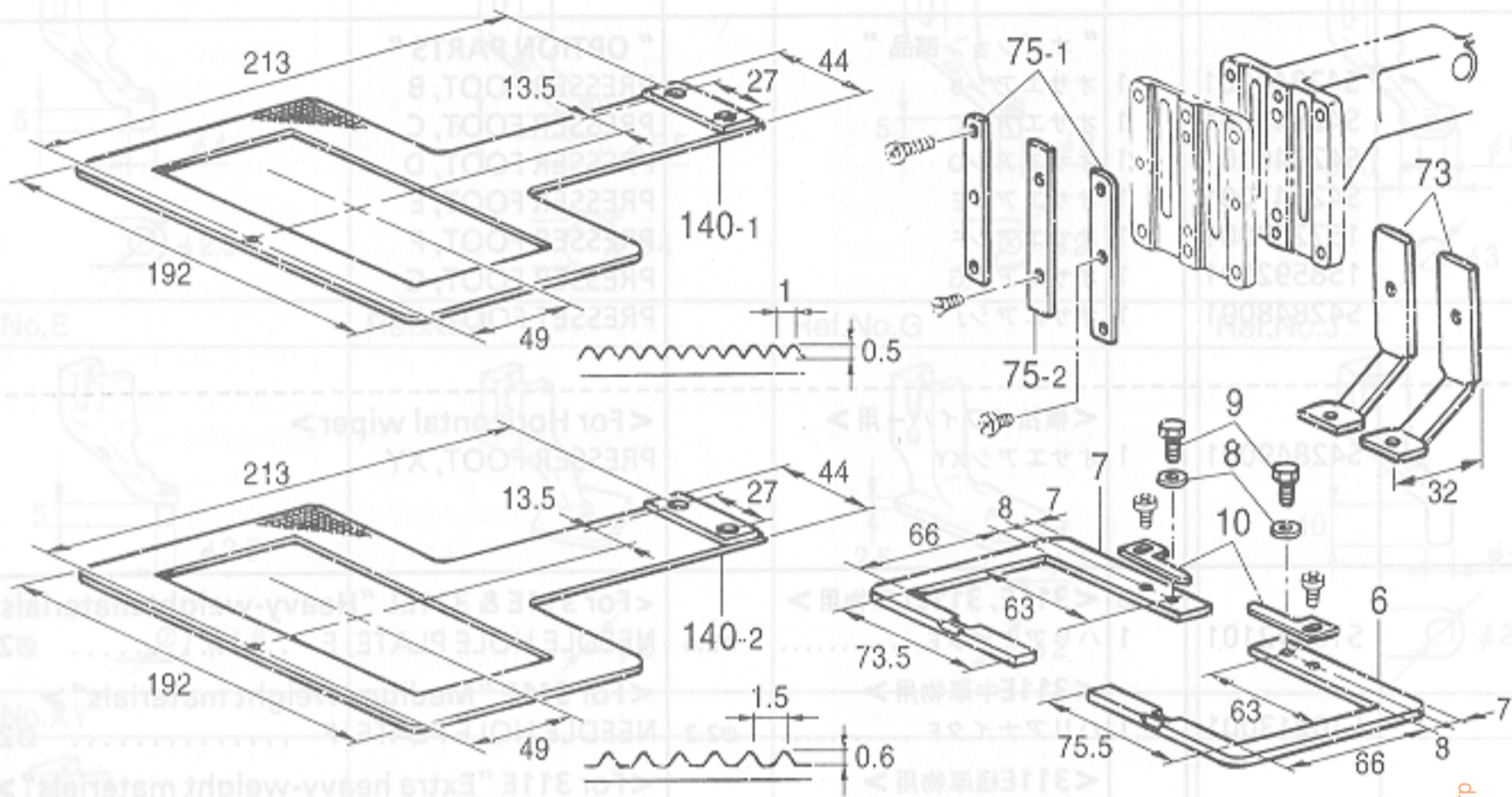

" オプション部品 / OPTION PARTS "

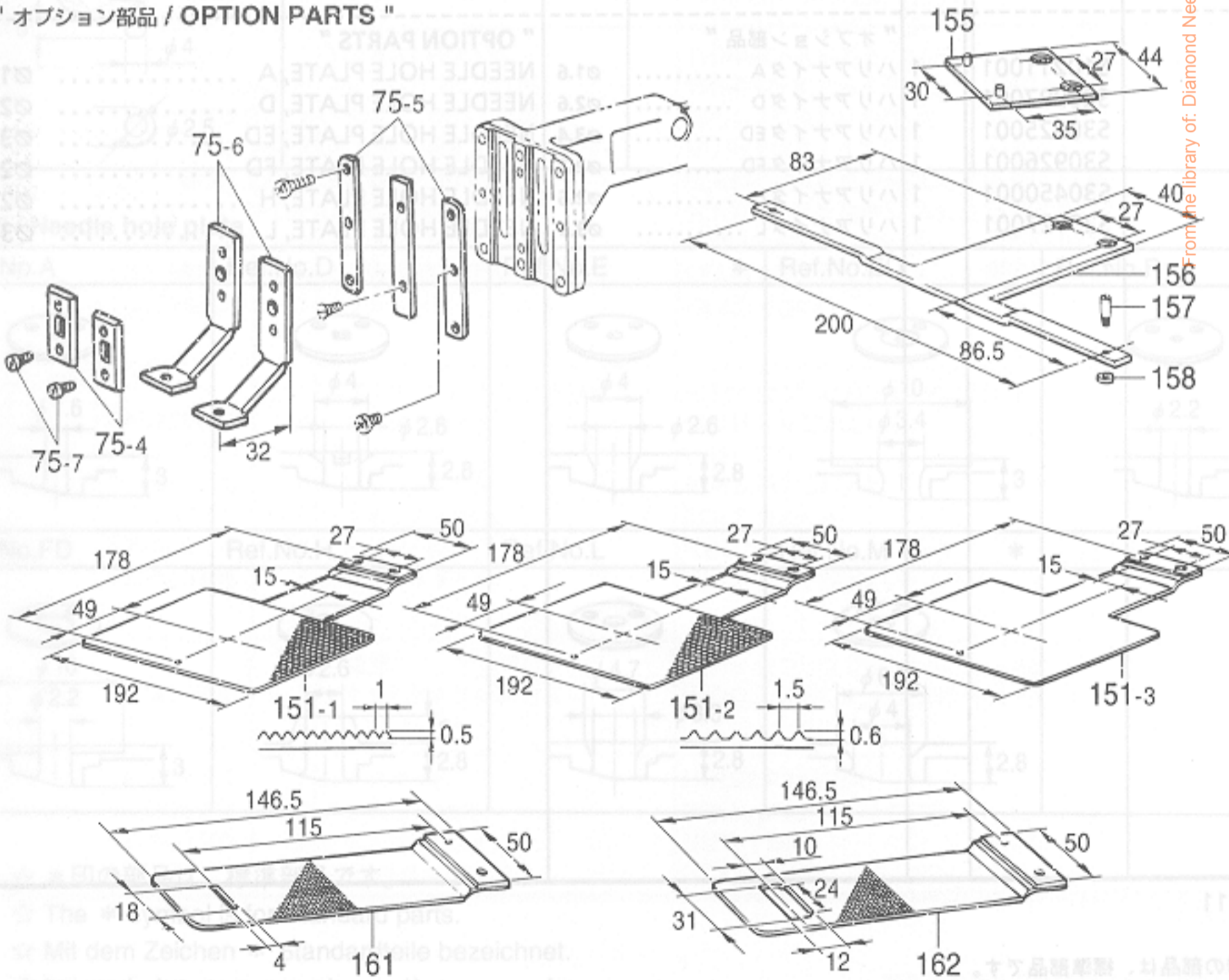

From the library of: Diamond Needle Corp

Ga2. ゲージ部品一覧表 (311E) / Gauge parts List (311E) / Lehrenliste (311E) / Liste des Pièces de cartent (311E) / Lista d'ePiezas de calibradores (311E)

REF.NO.	CODE	Q'TY	ヒンメイ	NAME OF PARTS	RM
6	S42772001	1	311オサエR	WORK CLAMP, R 311	※
7	S42773001	1	311オサエL	WORK CLAMP, L 311	※
8	025680232	2	ヒラザガネチユウ4.37	WASHER, PLAIN M 4.37	※
9	153403002	2	ボルト4.37X7	BOLT, SM4.37X7	※
10	S10065001	2	イチギメイタ	POSITIONING PLATE	※
73	S42801001	2	オサエアシSE	WORK CLAMP, SE	※
75-1	S42787001	2	オサエアシオサエイタA	WORK CLAMP GUIDE BRACKET, A	※
75-2	S42884001	1	オサエアシオサエイタB	WORK CLAMP GUIDE BRACKET, B	※
140-1	S42777001	1	<中厚物用> オクリイタ311A t=1.2	<For Medium-weight materials> FEED PLATE, 311 A t=1.2	※
140-2	S42797001	1	<厚物, 極厚物用> オクリイタ311B t=1.2	<For Heavy & extra heavy-weight materials> FEED PLATE, 311 B t=1.2	※
75-3	S42798001	1	" オプション部品 " オサエアシオサエイタ	" OPTION PARTS " WORK CLAMP GUIDE BRACKET	
75-4	S42799001	2	オサエチヨウセツイタ	WORK CLAMP AJUSTING PLATE	
75-5	S42800001	2	オサエスキマチヨウセツイタ	ADJUSTING PLATE	
75-6	S42802001	2	オサエアシSE-OP	WORK CLAMP, SE-OP	
75-7	062670512	4	ナベコ357-40X5	SCREW, PAN SM3.57-40X5	
155	S14841001	1	<ワンタッチ押し工用> OTオクリイタダイクミ	<For One-touch work clamp> OT-FEED PLATE BRACKET ASSY	
156	S13006001	1	カセットシジイタ	HOLDER PLATE, CASSETTE	
157	S13007001	2	カセットシジピン	PIN, CASSETTE HOLDER	
158	021660306	2	3シユナツト318-40	NUT, 3 SM3.18-40	
151-1	S43700001	1	<送り板ブランク材> OTオクリイタAブランク t=1.2	<OT-feed plate blank> OT-FEED PLATE BLANK, A t=1.2	
151-2	S43821001	1	OTオクリイタBブランク t=1.2	OT-FEED PLATE BLANK, B t=1.2	
151-3	S43822001	1	OTオクリイタCブランク t=1.2	OT-FEED PLATE BLANK, C t=1.2	
161	S14253001	1	<デニム用> OTオクリイタDE t=1.2	<For Denim> OT-FEED PLATE BLANK, DE t=1.2	
162	S14252001	1	<一般用> OTオクリイタST t=1.2	<For General> OT-FEED PLATE t=1.2	

From the library of: Diamond Needle Corp

151-V11

☆ ※印の部品は、標準部品です。
 ☆ The ※ symbol is for Standard parts.
 ☆ Mit dem Zeichen ※ Standardteile bezeichnet.
 ☆ Le symbol ※ correspond aux pièces normales.
 ☆ El asterisco ※ es para piezas normales

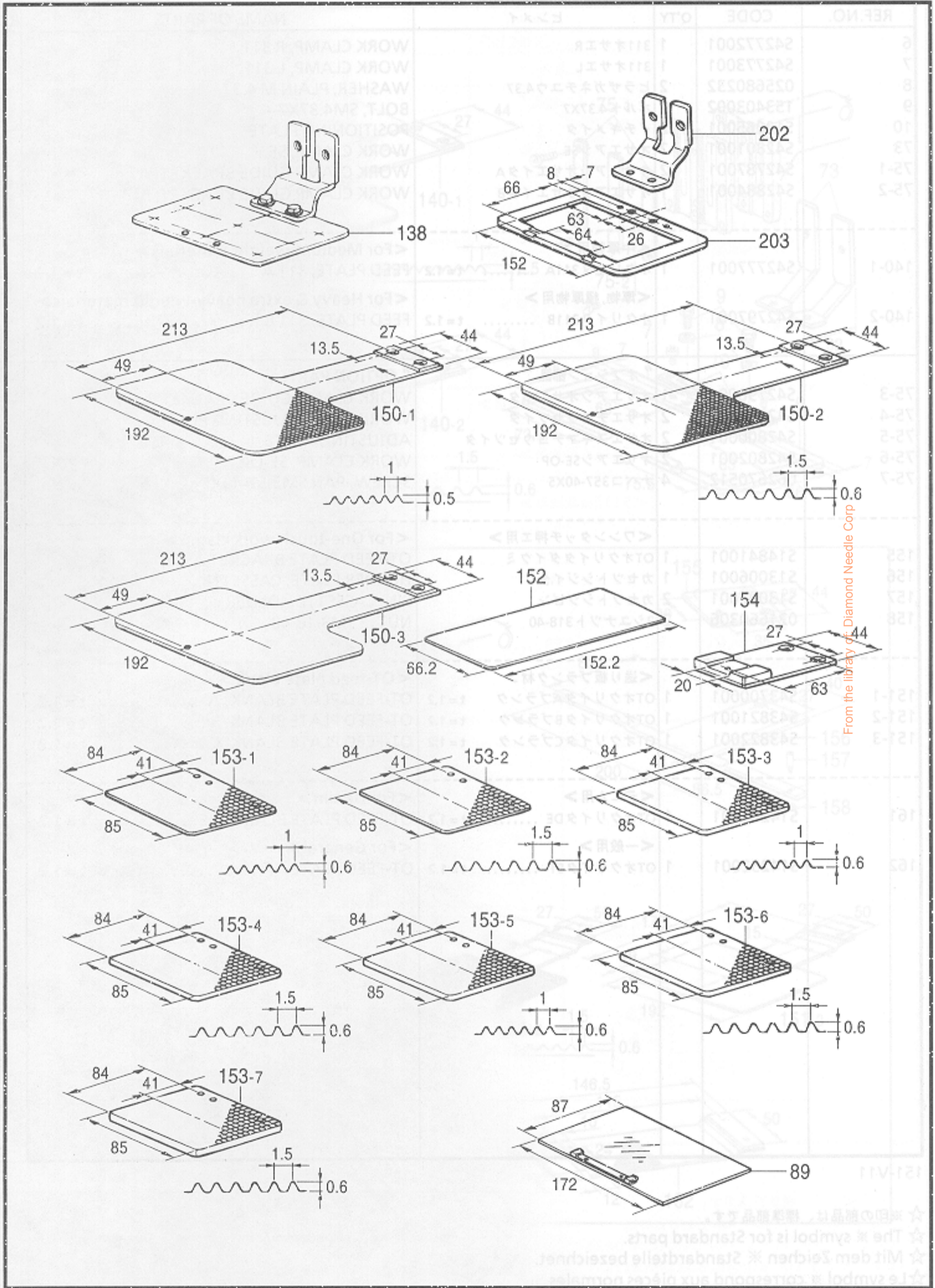

From the library of Diamond Needle Corp

Ga3. ゲージ部品一覧表 (311E) / Gauge parts List (311E) / Lehrenliste (311E)
 / Liste des Pièces de cartment (311E) / Lista d'ePiezas de calibradores (311E)

REF.NO.	CODE	Q'TY	ヒンメイ	NAME OF PARTS	RM
138	S42888001	1	<ゲージ部品> ゲンテンキジユンイタクミ	<For Gauge parts> H-POSITION STANDARD PLATE ASSY WASHER, PLAIN M 4.37	※
150-1 150-2 150-3 152 154	S43697001 S43698001 S43699001 S43823001 S12586001	1 1 1 1 1	<送り板用アタッチメント> オクリイタ311Aブランク t=1.2 オクリイタ311Bブランク t=1.2 オクリイタ311Cブランク t=1.2 オクリイタインナープレート オクリイタトリツケダイ	<For Feed plate attachment> FEED PLATE BLANK, A 311 t=1.2 FEED PLATE BLANK, B 311 t=1.2 FEED PLATE BLANK, C 311 t=1.2 FEED PLATE INNER PLATE FEED PLATE SETTING BRACKET	
153-1 153-2 153-3 153-4 153-5 153-6 153-7	S43824001 S43825001 S43826001 S43827001 S43828001 S43829001 S43830001	1 1 1 1 1 1 1	<押工用ブランク材> オサエブランクA-3.2 t=3.2 オサエブランクB-3.2 t=3.2 オサエブランクA-4.0 t=4.0 オサエブランクB-4.0 t=4.0 オサエブランクA-5.0 t=5.0 オサエブランクB-5.0 t=5.0 オサエブランクC-6.0 t=6.0	<The Blank for work clamp> WORK CLAMP BLANK, A-3.2 t=3.2 WORK CLAMP BLANK, B-3.2 t=3.2 WORK CLAMP BLANK, A-4.0 t=4.0 WORK CLAMP BLANK, B-4.0 t=4.0 WORK CLAMP BLANK, A-5.0 t=5.0 WORK CLAMP BLANK, B-5.0 t=5.0 WORK CLAMP BLANK, 6.0 t=6.0	
89 89 89	S43691001 S43691002 S43691003	1 1 1	ワンタッチ押工板組<> 311OTオサエイタクミ ... t=0.5 311OTオサエイタクミ ... t=1.0 311OTオサエイタクミ ... t=2.0	<One-touch cassette clamp assy> CASSETTE CLAMP ASSY, OT 311 ... t=0.5 CASSETTE CLAMP ASSY, OT 311 ... t=1.0 CASSETTE CLAMP ASSY, OT 311 ... t=2.0	
202 203	S43986001 S43987001	1 1	オサエアシUN 311オサエUN	WORK CLAMP, UN WORK CLAMP, 311 UN	

151-V11

- ☆ RM欄に※が付いている部品は、精密な組立て調整がして有りますので絶対に分解しないで下さい。
- ☆ Parts which have an asterisk (※) in the RM column are parts which have been assembled and adjusted to high precisions. These parts should never be disassembled.
- ☆ Die in der Kolonne RM mit einem Asteriskus (※) bezeichneten Teile sind mit hoher präzision zusammengebaut und eigestellt worden. Aus diesem Grunde dürfen diese Teile niemals zerlegt werden.
- ☆ Les pièces désignées par un astérisque (※) dans la colonne RM sont des pièces qui ont été assemblées et réglées avec une grande précision. Il ne faut en aucun cas déposer ces pièces.
- ☆ Las partes que tienen un asterisco (※) en la columna RM son las partes que han sido armadas y ajustadas a alta precisión. Estas partes nunca deberán ser desarmadas.

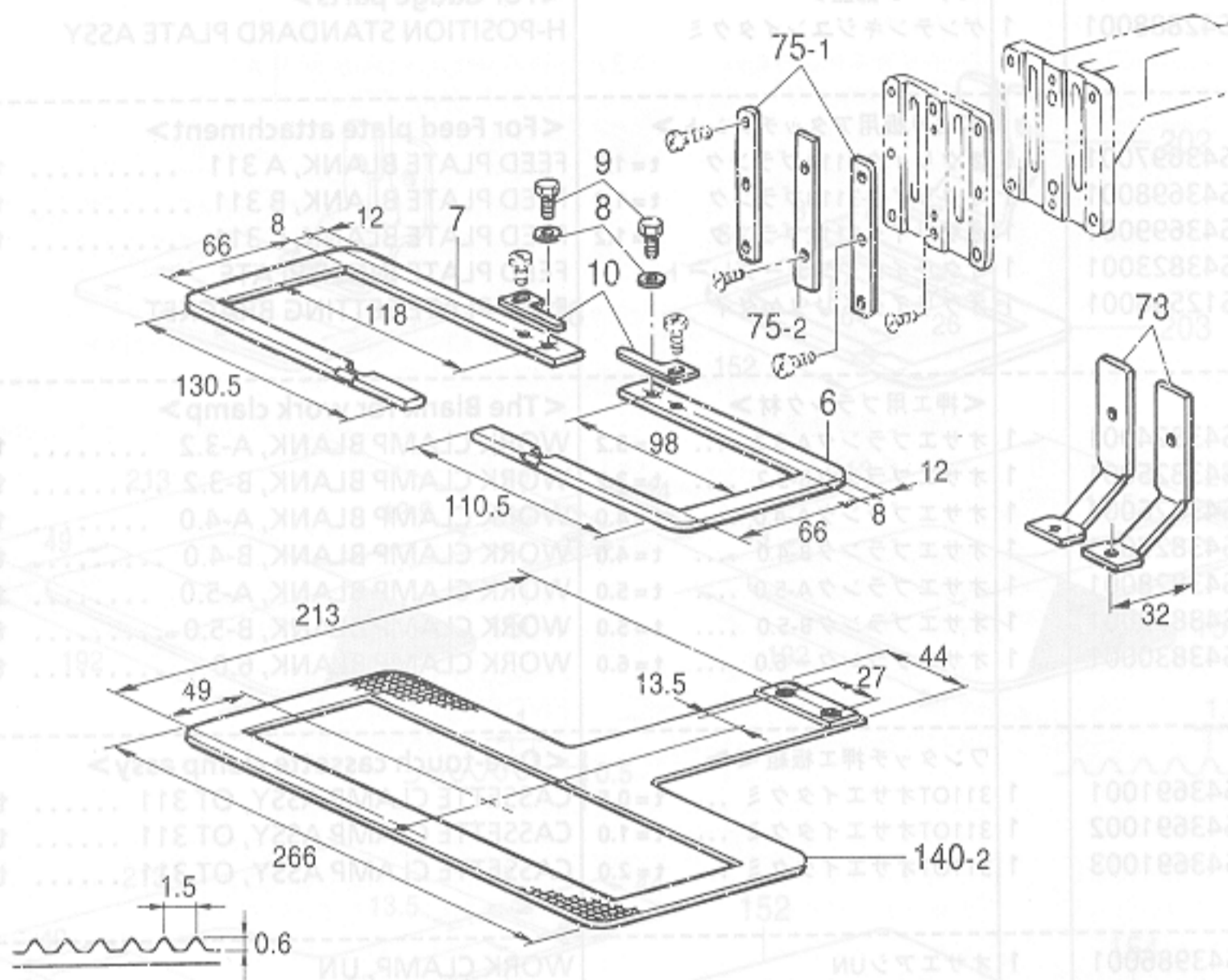

" オプション部品 / OPTION PARTS "

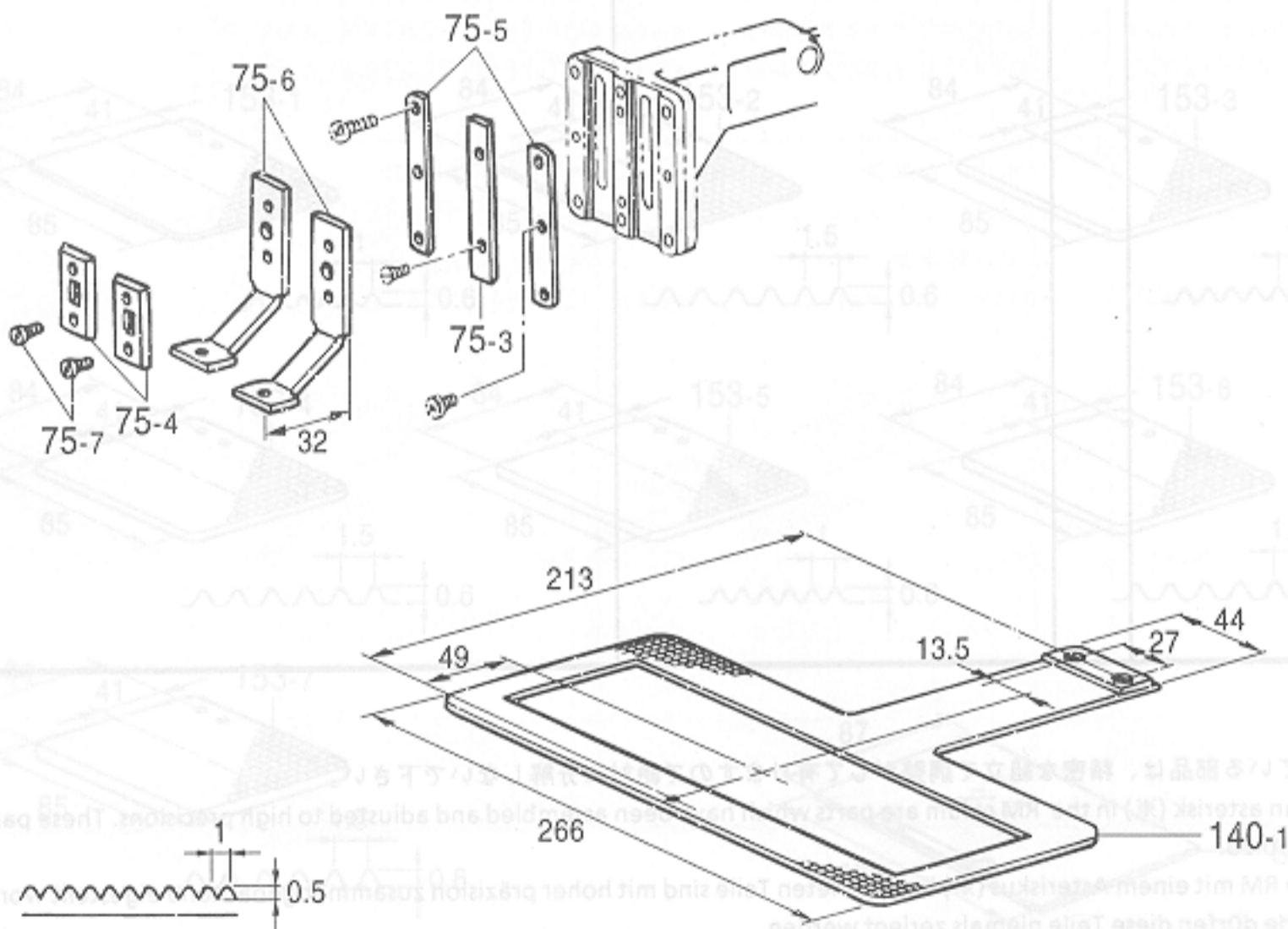

From the library of: Diamond Needle Corp

Ga4. ゲージ部品一覧表 (311EL) / Gauge parts List (311EL) / Lehrenliste (311EL)
 / Liste des Pièces de cartment (311EL) / Lista d'ePiezas de calibradores (311EL)

REF.NO.	CODE	Q'TY	ヒンメイ	NAME OF PARTS	RM
6	S44614001	1	311LオサエR	WORK CLAMP, R 311L	※
7	S44613001	1	311LオサエL	WORK CLAMP, L 311L	※
8	025680232	2	ヒラザガネチユウ4.37	WASHER, PLAIN M 4.37	※
9	153403002	2	ボルト4.37X7	BOLT, SM4.37X7	※
10	S10065001	2	イチギメイタ	POSITIONING PLATE	※
73	S42801001	2	オサエアシSE	WORK CLAMP, SE	※
75-1	S42787001	2	オサエアシオサエイタA	WORK CLAMP GUIDE BRACKET, A	※
75-2	S42884001	1	オサエアシオサエイタB	WORK CLAMP GUIDE BRACKET, B	※
140-2	S44622001	1	<厚物用> オクリイタ311LB t=1.2	<For Heavy-weight materials> FEED PLATE, B 311L t=1.2	※
75-3	S42798001	1	" オプション部品 "	" OPTION PARTS "	
75-4	S42799001	2	オサエアシオサエイタ	WORK CLAMP GUIDE BRACKET	
75-5	S42800001	2	オサエチヨウセツイタ	WORK CLAMP AJUSTING PLATE	
75-6	S42802001	2	オサエスキマチヨウセツイタ	ADJUSTING PLATE	
75-7	062670512	4	ナベコ357-40X5	SCREW, PAN SM3.57-40X5	
140-1	S44621001	1	<中厚物用> オクリイタ311LA t=1.2	<For Medium-weight materials> FEED PLATE, A 311L t=1.2	
153-1	S45604001	1	オサエブランクLA-3.2L	WORK CLAMP BLANK, A-3.2L 311L	
153-2	S45605001	1	オサエブランクLA-3.2R	WORK CLAMP BLANK, A-3.2R 311L	
153-3	S45606001	1	オサエブランクLB-3.2L	WORK CLAMP BLANK, B-3.2L 311L	
153-4	S45607001	1	オサエブランクLB-3.2R	WORK CLAMP BLANK, B-3.2R 311L	
153-1	S45608001	1	オサエブランクLA-4.0L	WORK CLAMP BLANK, A-4.0L 311L	
153-2	S45609001	1	オサエブランクLA-4.0R	WORK CLAMP BLANK, A-4.0R 311L	
153-3	S45610001	1	オサエブランクLB-4.0L	WORK CLAMP BLANK, B-4.0L 311L	
153-4	S45611001	1	オサエブランクLB-4.0R	WORK CLAMP BLANK, B-4.0R 311L	
153-1	S45612001	1	オサエブランクLA-5.0L	WORK CLAMP BLANK, A-5.0L 311L	
153-2	S45613001	1	オサエブランクLA-5.0R	WORK CLAMP BLANK, A-5.0R 311L	
153-3	S45614001	1	オサエブランクLB-5.0L	WORK CLAMP BLANK, B-5.0L 311L	
153-4	S45615001	1	オサエブランクLB-5.0R	WORK CLAMP BLANK, B-5.0R 311L	
153-3	S45616001	1	オサエブランクL-6.0L	WORK CLAMP BLANK, L-6.0L 311L	
153-4	S45617001	1	オサエブランクL-6.0R	WORK CLAMP BLANK, L-6.0R 311L	

From the library of: Diamond Needle Corp

151-V12

Die in der Kolonne RM mit einem Asteriskus (※) bezeichneten Teile sind nie zusammengebaut und eingestellt worden.
 ☆ ※印の部品は、標準部品です。
 ☆ The ※ symbol is for Standard parts.
 ☆ Mit dem Zeichen ※ Standardteile bezeichnet.
 ☆ Le symbol ※ correspond aux pièces normales.
 ☆ El asterisco ※ es para piezas normales.

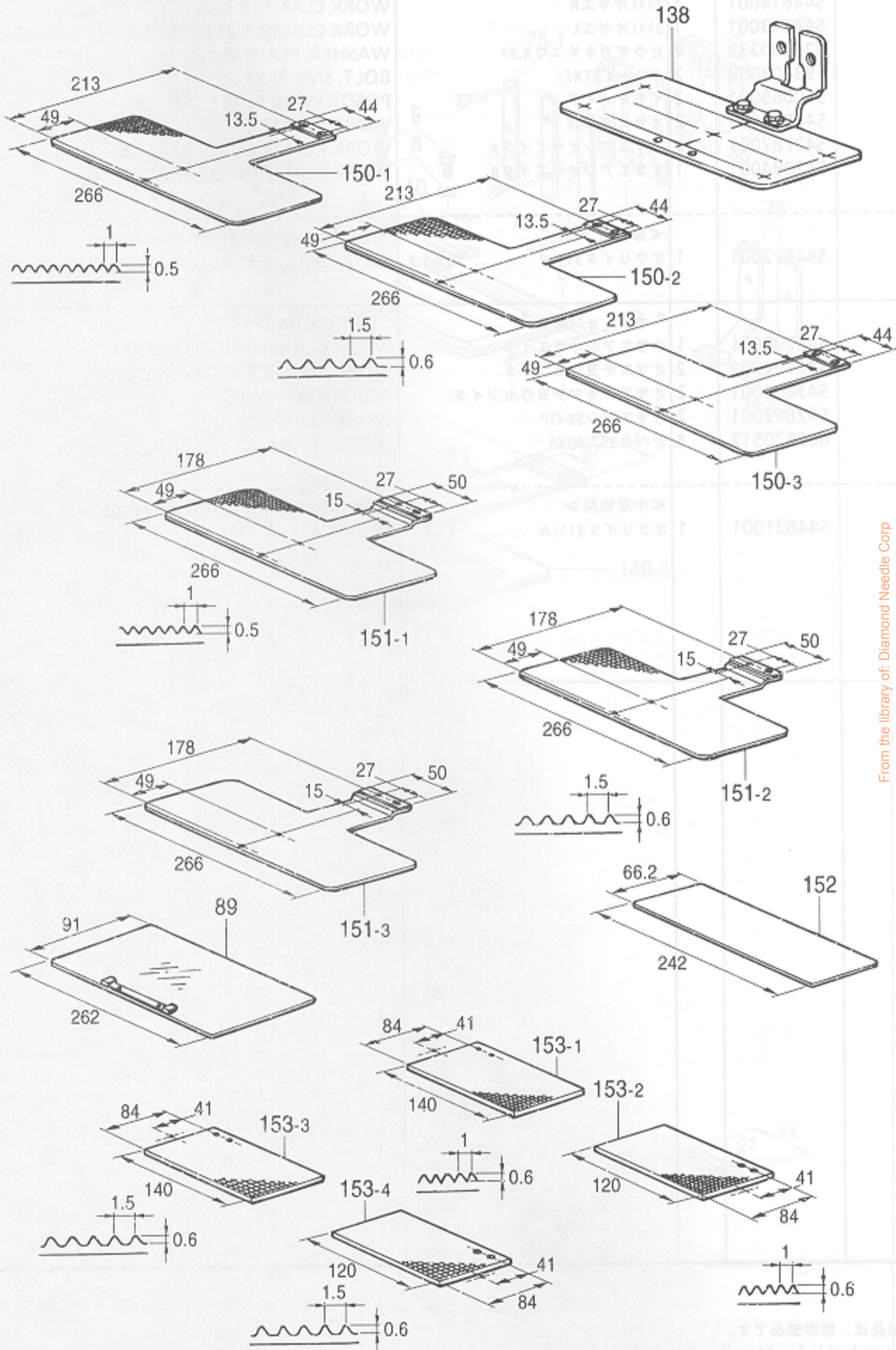

From the library of: Diamond Needle Corp

Ga5. ゲージ部品一覧表 (311EL) / Gauge parts List (311EL) / Lehrenliste (311EL)
 / Liste des Pièces de cartment (311EL) / Lista d'ePiezas de calibradores (311EL)







REF.NO.	CODE	Q'TY	ヒンメイ	NAME OF PARTS	RM
			" オプション部品 "	" OPTION PARTS "	
89	S45591001	1	<ワンタッチ押工板組> 311LOTオサエイタクミ05 t=0.5	<One-touch cassette clamp assy> CASSETTE CLAMP ASSY, OT 311L t=0.5	
89	S45593001	1	311LOTオサエイタクミ10 t=1.0	CASSETTE CLAMP ASSY, OT 311L t=1.0	
89	S45595001	1	311LOTオサエイタクミ20 t=2.0	CASSTTE CLAMP ASSY, OT 311L t=2.0	
138	S44608001	1	<ゲージ部品> ゲンテンキジユンイタクミ	<For Gauge parts> H-POSITION STANDARD PLATE ASSY	※
150-1	S45597001	1	<送り板用アタッチメント> オクリイタ311LAブランク t=1.2	<For Feed plate attachment> FEED PLATE BLANK, A 311L t=1.2	
150-2	S45598001	1	オクリイタ311LBブランク t=1.2	FEED PLATE BLANK, B 311L t=1.2	
150-3	S45599001	1	オクリイタ311LCブランク t=1.2	FEED PLATE BLANK, C 311L t=1.2	
152	S45603001	1	オクリイタインナープレート	FEED PLATE INNER PLATE	
151-1	S45600001	1	<ワンタッチ押工用> OTオクリイタLAブランク t=1.2	<For One-touch work clamp> OT-FEED PLATE BLANK, A 311L t=1.2	
151-2	S45601001	1	OTオクリイタLBブランク t=1.2	OT-FEED PLATE BLANK, B 311L t=1.2	
151-3	S45602001	1	OTオクリイタLCブランク t=1.2	OT-FEED PLATE BLANK, C 311L t=1.2	
153-1	S45604001	1	<押工用ブランク材> <板厚3.2mm><> オサエブランクLA-3.2L	<The Blank for work clamp> <Thick = 3.2mm> WORK CLAMP BLANK, A-3.2L 311L	
153-2	S45605001	1	オサエブランクLA-3.2R	WORK CLAMP BLANK, A-3.2R 311L	
153-3	S45606001	1	オサエブランクLB-3.2L	WORK CLAMP BLANK, B-3.2L 311L	
153-4	S45607001	1	オサエブランクLB-3.2R	WORK CLAMP BLANK, B-3.2R 311L	
153-1	S45608001	1	<板厚4.0mm> オサエブランクLA-4.0L	<Thick = 4.0mm> WORK CLAMP BLANK, A-4.0L 311L	
153-2	S45609001	1	オサエブランクLA-4.0R	WORK CLAMP BLANK, A-4.0R 311L	
153-3	S45610001	1	オサエブランクLB-4.0L	WORK CLAMP BLANK, B-4.0L 311L	
153-4	S45611001	1	オサエブランクLB-4.0R	WORK CLAMP BLANK, B-4.0R 311L	
153-1	S45612001	1	<板厚5.0mm> オサエブランクLA-5.0L	<Thick = 5.0mm> WORK CLAMP BLANK, A-5.0L 311L	
153-2	S45613001	1	オサエブランクLA-5.0R	WORK CLAMP BLANK, A-5.0R 311L	
153-3	S45614001	1	オサエブランクLB-5.0L	WORK CLAMP BLANK, B-5.0L 311L	
153-4	S45615001	1	オサエブランクLB-5.0R	WORK CLAMP BLANK, B-5.0R 311L	
153-3	S45616001	1	<板厚6.0mm> オサエブランクL-6.0L	<Thick = 6.0mm> WORK CLAMP BLANK, 6.0L 311L	
153-4	S45617001	1	オサエブランクL-6.0R	WORK CLAMP BLANK, 6.0R 311L	

From the library of: Diamond Needle Corp

151-V12

- ☆ RM欄に※が付いている部品は、精密な組立て調整がして有りますので絶対に分解しないで下さい。
- ☆ Parts which have an asterisk (※) in the RM colum are parts which have been assembled and adjusted to high precisions. These parts should never be disassembled.
- ☆ Die in der Kolonne RM mit einem Asteriskus (※) bezeichneten Teile sind mit hoher präzision zusammengebaut und eigestellt worden. Aus diesem Grunde dürfen diese Teile niemals zerlegt werden.
- ☆ Les pièces désignées par un astérisque (※) dans la colonne RM sont des pièces qui ont été assemblées et réglées avec une grande précision. Il ne faut en aucun cas déposer ces pièces.
- ☆ Las partes que tienen un asterisco (※) en la columna RM son las partes que han sido armadas y ajustadas a alta precisión. Estas partes nunca deberán ser desarmadas.

Wa. 警告ラベル / Warning labels / Warnschilder / Etiquettes d'avertissement / Etiquetas de advertencia

警告ラベル / Warning labels	品名 / Name of Parts	Size(mm)	Code
	電撃ラベル・和	40X64	S38353-101
	Label, elec. shock 4 lang.	35X118	S38352-101
	操作注意ラベル・BAS 和	52X84	S38357-002
	Label, operation (BAS) Eng.	52X84	S38571-002
	PEマーク Mark, PE	7.5X12.5	S37059-001
	アースマーク Mark, grounding	φ 12	S37060-001

From the library of: Diamond Needle Corp.

索引 / INDEX / VERZEICHNIS
/ INDEX / INDICE

CODE	REF.NO.	Page
S00313009	D1 - 69	34
S00480000	P - 44-2	64
S00554000	M - 1-18	56
S00617000	Z - 53	93
S00705001	J - 47	50
S01005000	Z - 34-4-4	93
S01199003	U1 - 5	76
	U2 - 5	78
S02269001	B - 20	8
S02337001	U1 - 2	76
	U2 - 2	78
S02354001	J - 23	48
S02429101	E - 14-1-2	38
S02438001	G - 25-1	44
S02439001	G - 25-3	44
S02444101	C3 - 67	18
S02445001	A1 - 31	2
	A2 - 31	4
S02617001	AA1- 2-1-7	86
S02652001	J - 6	48
S02654001	J - 7-1	48
S02672002	K - 21	52
S02677001	K - 23	52
S02678001	K - 25	52
S02680001	AA2- 3-1-13	88
S02739000	U1 - 1-9	74
S02740000	U1 - 1-8	74
S02747101	Z - 34-4-5	93
S02763302	Z - 34	93
S02777001	Z - 34-4	93
S02778002	Z - 34-9	93
S02786002	Z - 34-10	93
S02787002	Z - 34-10-1	93
S02873001	C3 - 70	18
S02907000	S - 1-8	68
S03677001	D2 - 66	36
S03704002	E - 13	38
S03800001	C1 - 1-2-15	12
	C4 - 1-15	20
S03801101	C1 - 1-2-17	12
	C4 - 1-17	20
S03803000	Y - 1-13	84
S04897000	AA2- 4-4	88
	AA2- 5-4	88
S05223001	U1 - 1-2-1-6	74
	U1 - 1-2-2-6	74
S05665001	Y - 1-1-9	84
S05670002	N - 12	60
S06706001	Z - 15	92
S07333001	F - 2	42
S07456000	F - 3	42
S07783001	Z - 61	93
S07818009	P - 23	64
S08030000	M - 1-29-4	56
	Z - 24	92
S08140000	AA2- 5-3	88
S09043000	F - 31	42
	F - 45	42
S09216002	U1 - 1-2-1-1	74
S09217102	U1 - 1-2-1-2	74
S09221002	U1 - 1-2-2-1	74
S09222102	U1 - 1-2-2-2	74
S09224002	N - 30	62

CODE	REF.NO.	Page
S09224002	U1 - 1-2-7	74
S09225001	N - 31	62
	U1 - 1-2-8	74
S09226001	N - 34	62
	U1 - 1-2-11	74
S09228000	N - 1-1-4	60
	N - 1-2-4	60
S09312001	U1 - 1-2-1-5	74
	U1 - 1-2-2-5	74
S09318101	N - 1-1-2	60
	N - 1-2-2	60
S09393002	N - 12	60
S09639009	U1 - 1-2-1	74
S09640009	U1 - 1-2-2	74
S09989000	Z - 72	94
S10030002	A1 - 24	2
	A2 - 24	4
S10047001	C1 - 1-1-2	12
S10048001	C1 - 1-1-3	12
S10049001	C1 - 1-1-5	12
S10050000	C1 - 1-1-6	12
S10053001	C1 - 1-1-9	12
S10058001	C1 - 1-1-14	12
	C1 - 1-2-5	12
	C4 - 1-5	20
S10059001	C1 - 1-1-21	12
S10065001	C1 - 10	14
	C4 - 10	20
	Ga2 - 10	98
	Ga4 - 10	102
S10069101	C2 - 12-2	16
	C5 - 12-2	22
S10077100	C2 - 31	16
	C5 - 31	22
S10078001	C2 - 32	16
	C3 - 121	18
	C5 - 32	22
	C6 - 121	24
S10079101	C2 - 33	16
	C3 - 122	18
	C5 - 33	22
S10083001	C2 - 40	16
	C5 - 40	22
S10087101	C3 - 112	18
S10091101	C3 - 65	18
	C6 - 65	24
S10103001	D1 - 17	34
S10105001	D1 - 20	34
S10108001	D1 - 29	34
S10109001	D1 - 32	34
S10110101	D1 - 34	34
S10111101	D2 - 57	36
S10112001	D2 - 58	36
S10113201	D2 - 59	36
S10125009	D1 - 38	34
S10133000	C3 - 110	18
S10134001	C3 - 111	18
S10140109	C2 - 85	16
	C5 - 85	22
S10141109	A1 - 15	2
	A2 - 15	4
S10162201	F - 15	42
S10174000	H - 1-15	46

CODE	REF.NO.	Page
S10189001	J - 18	48
S10195001	J - 30	48
S10202101	J - 41	48
S10203101	J - 43	48
S10204101	J - 44	48
S10205001	J - 45-1	48
S10208001	J - 46	50
	Z - 18	92
S10208002	J - 46	50
	Z - 18	92
S10208003	J - 46	50
	Z - 18	92
S10209101	J - 48	50
S10210101	J - 49-1	50
S10211001	J - 53-1	50
	Ga1 - A	96
S10212101	J - 53-3	50
	Ga1 - E	96
S10213001	J - 53-5	50
	Ga1 - F	96
S10214109	K - 5-1	52
	AA2 - 3-1-3	88
S10215109	K - 8-1	52
S10217001	K - 13	52
S10219001	L - 1	54
S10221001	L - 7	54
S10229101	L - 15	54
S10230000	L - 21	54
S10231001	L - 23	54
S10232001	L - 27	54
S10239001	L - 30	54
S10243000	P - 9	64
S10244000	P - 21-1	64
S10352101	C3 - 136	18
	C6 - 136	24
S10371001	D2 - 61	36
S10372100	D2 - 62	36
S10379001	C1 - 1-2-12	12
	C4 - 1-12	20
S10408000	S - 8	68
S10445000	C7 - 141-1-1	26
S10446000	C7 - 141-i-2	26
S10447000	C7 - 141-2-1	26
S10448000	C7 - 141-2-2	26
S10449000	C7 - 141-2-3	26
S10450000	C7 - 141-1-3	26
S10451000	C7 - 141-2-4	26
S10452000	C7 - 141-1-6	26
S10453000	C7 - 141-2-5	26
S10454000	C7 - 141-1-4	26
S10455000	C7 - 141-2-6	26
S10456000	C7 - 141-1-7	26
S10457000	C7 - 141-2-7	26
S10458000	C7 - 141-1-5	26
S10459000	C7 - 141-2-8	26
S10460000	C7 - 141-1-8	26
S10461000	C7 - 141-2-9	26
S10470101	K - 17	52
S10472001	Z - 75	94
S10478000	F - 10	42
S10661109	U1 - 1-2-1-8	74
	U1 - 1-2-2-8	74
S11182009	G - 13	44

From the Library of Diamond Needle Corp

CODE	REF.NO.	Page
S11884001	AA1- 2-1-5	86
S12004000	C1 - 1-1-23	12
	C1 - 1-2-19	12
	C2 - 26	16
	C4 - 1-19	20
	C5 - 26	22
S12104000	AA2- 5-2	88
S12150000	AA3- 2-1-3	90
S12212000	N - 10	60
S12404000	N - 1-1-5-2-1	60
	N - 1-2-5-2-1	60
S12441001	G - 32	44
S12586001	C9 - 154	30
	Ga3 - 154	100
S12633209	Y - 1-1	84
S12634009	Y - 1-1-1	84
S12635009	Y - 1-1-2	84
S12636001	Y - 1-1-3	84
S12637009	Y - 1-1-17	84
S12638009	Y - 1-1-6	84
S12639001	Y - 1-1-18	84
S12640009	Y - 1-1-20	84
S12641009	Y - 1-1-4	84
S12642009	Y - 1-1-19	84
S12643001	Y - 1-2	84
S12645001	Y - 1-10	84
S12647001	Y - 1-11-9	84
S12668001	K - 33	52
S12699000	G - 11	44
S13006001	C8 - 156	28
	Ga2 - 156	98
S13007001	C8 - 157	28
	Ga2 - 157	98
S13090001	C8 - 166	28
S13091001	C8 - 167	28
S13092001	C8 - 165	28
S13096001	C8 - 169	28
S13097001	C8 - 170	28
S13098001	C8 - 168	28
S13099001	Y - 2	84
	C7 - 200	26
S13100001	Y - 3	84
	C7 - 201	26
S13385001	K - 30	52
S13399001	D2 - 65	36
S13807000	C7 - 141-2	26
S14069001	C9 - 195	30
S14073001	C9 - 197	30
S14252001	C8 - 162	28
	Ga2 - 162	98
S14253001	C8 - 161	28
	Ga2 - 161	98
S14254001	C8 - 159	28
S14255001	C8 - 160	28
S14598001	Y - 4	84
S14841001	X - 2	82
	C8 - 155	28
	Ga2 - 155	98
S14846001	C8 - 163	28
S14848001	C9 - 189	30
S14849001	C9 - 190	30
S15031008	AA2- 3-3	88
	AA2- 4-2	88

CODE	REF.NO.	Page
S15031008	AA3- 2-4	90
S15158009	U1 - 1-7	74
S15662992	E - 22-1	38
S15663991	E - 22-1	38
S15665001	E - 25	38
	Z - 16	92
S15666001	E - 25	38
	Z - 16	92
S15667001	E - 24-1-3	38
	E - 24-1-3	38
	E - 24-2-3	40
S15902401	E - 24-1	38
S15903401	E - 24-1	38
S16074101	E - 24-1-1	38
S16075101	E - 24-1-1	38
S16492101	E - 24-1-2	38
	E - 24-1-2	38
	E - 24-2-2	40
S16568000	M - 1-8	56
S17803001	A1 - 34	2
	A2 - 34	4
S17871101	D2 - 46	36
S17885101	C6 - 106	24
S17886100	C6 - 110	24
S17887001	C6 - 111	24
S17888001	C6 - 112	24
S17890001	C6 - 122	24
S17901000	F - 47	42
S17942000	AA2- 3-1-1	88
S18027101	AA2- 4-1	88
S18032001	AA1- 1-1-1	86
S18037009	AA1- 1-1-12	86
S18093100	F - 18	42
	F - 25	42
	Z - 4-4	92
S18415101	N - 1-1-5-1-3	60
	N - 1-2-5-1-3	60
	Y - 1-1-25	84
	Y - 1-11-8	84
	C1 - 1-2-14	12
	C4 - 1-14	20
	AA1- 6-4	86
	AA2- 3-1-4	88
	AA2- 3-2-3	88
	AA2- 4-3-4	88
	AA3- 2-2-4	90
S18633109	U1 - 37	76
	U2 - 37	78
S18641009	Z - 85	94
S18707149	Z - 13	92
S19662001	D1 - 12	34
S19663001	D1 - 7	34
S20137001	U1 - 40	76
	U2 - 40	78
S20164009	A1 - 33	2
	A2 - 33	4
S20280101	X - 3-1	82
	X - 3-1	82
S20286101	X - 3-2	82
	X - 3-2	82
S20289101	X - 3-3	82
	X - 4-1	82
S20293101	X - 3-4	82

CODE	REF.NO.	Page
S20293101	X - 5-1	82
S20822101	X - 4	82
S20823101	X - 5	82
S21304001	D1 - 73	34
S21527001	F - 14	42
S21775001	C1 - 1-1-15	12
	C1 - 1-2-6	12
	C4 - 1-6	20
S21798001	Z - 34-8	93
S21875001	K - 32	52
S23818001	C8 - 171	28
S23819001	C8 - 172	28
S23820001	C8 - 173	28
S23821001	C8 - 174	28
S23822001	C8 - 175	28
S23823001	C8 - 176	28
S23824001	C8 - 177	28
S23825001	C8 - 178	28
S23826001	C8 - 179	28
S23827001	C8 - 180	28
S23828001	C8 - 181	28
S23829001	C8 - 182	28
S23830001	C8 - 183	28
S23831001	C8 - 184	28
S23832001	C8 - 185	28
S23833001	C8 - 186	28
S23834001	C8 - 187	28
S23835001	C8 - 188	28
S23836001	J - 7	48
S23880000	N - 1-1-10	60
	N - 1-2-9	60
S24511007	B - 24	10
S24612001	X - 1	82
S25100000	N - 26	60
	N - 26	62
S25127001	J - 53-8	50
	Ga1 - L	96
S25456001	K - 3	52
	K - 11	52
S25634101	S - 5	68
S27844101	C2 - 41	16
	C2 - 50	16
	C3 - 106	18
	C5 - 41	22
	C5 - 50	22
S28741000	Y - 1-14	84
S29023000	S - 1-2-1	68
S29468100	AA1- 2-1-4	86
S29704000	Y - 1-11-10	84
S29710000	N - 1-2-3	60
S29997001	J - 53-2	50
	Ga1 - D	96
S30015001	C9 - 192	30
S30033001	J - 21-3	48
S30128001	J - 49-2	50
S30260002	S - 1-2-2	68
S30450001	J - 53-7	50
	Ga1 - H	96
S30925001	J - 53-4	50
	Ga1 - ED	96
S30926001	J - 53-6	50
	Ga1 - FD	96
S31012001	D2 - 55	36

From the library of: Diamond Needle Corp

CODE	REF.NO.	Page
S31013001	D2 - 56	36
S31365000	C9 - 137	30
S31551009	N - 1-1-1	60
	N - 1-2-1	60
S31554009	AA1- 6-5	86
S31567101	C2 - 23	16
	C5 - 23	22
S31568000	C2 - 28	16
	C5 - 28	22
S31570209	Y - 1-11-1	84
S31612001	J - 45-4	50
S31674000	P - 32	64
S31760000	M - 1-19	56
S31776109	AA2- 3-1-8	88
S31777001	AA2- 3-1-2	88
S31778000	AA2- 3-1-6	88
S31779001	AA2- 3-1-7	88
S32129000	N - 13	62
S34348001	J - 53-9	50
S34413000	M - 1-28	56
S34533001	AA3- 2-1-4	90
S34534001	AA3- 2-1-5	90
S34536001	AA3- 2-1-12	90
S34706000	AA3- 2-1-1	90
S34986000	F - 11	42
S35722000	C2 - 47	16
	C5 - 47	22
S35723101	C2 - 49	16
	C5 - 49	22
S36008009	S - 1-18	68
S35260000	T1 - 1-5-2	70
	T1 - 2-9-2	70
	T2 - 3-5-2	72
S36685101	A1 - 50	2
S36686101	A1 - 50-1	2
S37037001	Z - 34-11-3	93
S37038001	Z - 34-11-2	93
S37057001	P - 36	64
S37058001	Wa	105
S37059001	M - 1-25	56
	Wa	105
S37050001	M - 1-26	56
	Wa	105
S37113001	A2 - 22-1-4	4
S37147109	K - 5-2	52
S37148109	K - 8-2	52
S37619001	A2 - 22-1-2	4
S37806109	K - 8-3	52
S37920009	A1 - 27	2
	A2 - 27	4
S37927000	B - 17	8
S37928019	B - 24	10
S37929009	B - 24	10
S37929016	B - 24	10
S37951001	D1 - 1	34
S37962101	D1 - 2	34
S37964101	D1 - 4	34
S37966101	D1 - 6	34
S37968001	D1 - 11	34
S37970050	D1 - 14	34
S37973201	D1 - 71	34
S37974000	D1 - 24	34
S37978151	E - 5	38

CODE	REF.NO.	Page
S37979101	E - 8	38
S37981051	E - 9	38
S37983001	F - 6	42
S37984000	F - 17	42
	F - 34	42
S37987001	F - 28	42
S37988000	F - 29	42
S37990309	H - 1	46
S37991109	H - 1-1	46
S37992100	H - 1-2	46
S37993000	H - 1-3	46
S37994001	H - 1-5	46
S37995101	H - 1-6	46
S37996001	H - 1-8	46
S37997001	H - 1-11	46
S37998001	H - 1-16	46
S38001001	J - 1	48
S38002101	J - 3	48
S38003001	J - 8	48
S38004002	J - 10	48
S38004003	J - 10	48
S38004004	J - 10	48
S38005001	J - 15	48
S38006001	J - 21	48
S38007001	J - 21-1	48
S38010001	J - 29	48
S38011001	J - 34	48
S38029000	T1 - 1-5	70
S38030000	T1 - 1-5-1	70
S38035109	B - 8	8
S38039109	Z - 4	92
S38040109	Z - 4-1	92
S38041000	U1 - 1-16	74
	U2 - 27	78
S38043009	Z - 20	92
S38059000	T1 - 1-20	70
	T1 - 2-24	70
	T2 - 3-20	72
S38060000	T1 - 1-19	70
	T1 - 2-23	70
	T2 - 3-19	72
S38072201	Q - 1	66
S38080001	Q - 4	66
S38082001	Q - 5	66
S38094100	M - 1-4	56
S38104000	S - 1-2-4	68
S38107100	M - 1-12	56
S38108000	M - 1-13	56
S38109100	M - 1-14	56
S38110000	M - 1-15	56
S38112001	M - 2-1	56
S38114000	M - 2-2	56
S38117000	M - 2-3	56
S38120000	M - 2-5	56
S38122200	M - 1-9	56
S38123000	M - 3-1	57
S38148000	P - 26	64
S38155000	R - 1-3	66
S38164000	R - 1-4	66
S38166000	T1 - 1-1	70
	T1 - 2-1	70
	T2 - 3-1	72
S38167001	T1 - 2-2	70

CODE	REF.NO.	Page
S38168001	T1 - 2-5	70
S38170001	T1 - 1-4	70
	T1 - 2-8	70
	T2 - 3-4	72
S38174000	T1 - 1-8	70
	T1 - 2-12	70
	T2 - 3-8	72
S38175001	T1 - 1-9	70
	T1 - 2-13	70
	T2 - 3-9	72
S38176001	T1 - 1-10	70
	T1 - 2-14	70
	T2 - 3-10	72
S38177001	T1 - 1-14	70
	T1 - 2-18	70
	T2 - 3-14	72
S38180000	T1 - 1-18	70
	T1 - 2-22	70
	T2 - 3-18	72
S38200000	M - 1-29-1	56
S38201000	M - 1-29-3	56
S38352101	M - 20	57
	Wa	105
S38353101	M - 21	57
	Wa	105
S38357002	Wa	105
S38571002	Wa	105
S38648001	Z - 34-4-2	93
S40616001	M - 40-1	57
S40621000	M - 40	57
	W - 1-20	80
S40622000	M - 51	57
S40623000	M - 52	57
S40624000	M - 40-2	57
S40628000	N - 1-1-3	60
S40629000	N - 1-1-9	60
S40635001	M - 40	57
S40640001	Z - 34-5	93
S40641001	Z - 34-11	93
S40764000	M - 52	57
S40837001	E - 14-2	40
	AB - 1-1	90
S40838001	E - 14-2-1	40
S40839001	E - 14-2-2	40
	AB - 1-1-1	90
S40840001	E - 19-2	40
	AB - 1-2	90
S40841101	E - 21-2	40
	AB - 1-3	90
S40842991	E - 22-2	40
	AB - 1-4	90
S40843001	E - 24-2	40
	AB - 1-5	90
S40845001	E - 24-2-1	40
	AB - 1-5-1	90
S40846001	J - 45-3	50
	AB - 1-6	90
S40886001	E - 14-1-1	38
S40934101	J - 45-2	50
S41202051	P - 24	64
S41205001	K - 2	52
S41206001	K - 1	52
S41207000	K - 4	52

CODE	REF.NO.	Page
S41222101	G - 25-2	44
S41239001	D1 - 15	34
S41271000	C1 - 1-2-21	12
	C4 - 1-21	20
S42258000	T1 - 2-9-1	70
S42259000	T1 - 2-9	70
S42260000	M - 1-10	56
S42512000	D1 - 74	34
S42653000	M - 1-27	56
	M - 53	57
	S - 1-15	68
S42658000	Z - 73	94
S42747101	D1 - 13	34
S42748009	A1 - 13	2
S42750109	A1 - 20	2
	A2 - 20	4
S42751009	A1 - 20-1	2
	A2 - 20-1	4
S42752000	A1 - 20-2	2
	A2 - 20-2	4
S42753001	A1 - 29	2
S42754001	B - 3	8
S42756001	B - 14-1-6	8
	B - 14-2-6	8
S42758001	A1 - 38	2
	A2 - 38	4
S42760101	C1 - 1-1	12
S42761000	C1 - 1-1-1	12
	C1 - 1-2-1	12
	C4 - 1-1	20
S42762001	C1 - 1-1-7	12
S42763001	C1 - 1-1-8	12
S42764001	C1 - 1-1-11	12
	C1 - 1-2-2	12
	C4 - 1-2	20
S42765001	C1 - 1-1-12	12
S42766001	C1 - 1-1-13	12
S42767001	C1 - 1-1-22	12
S42768101	C1 - 1-2	12
	C4 - 1	20
S42769001	C1 - 1-2-3	12
	C4 - 1-3	20
S42770001	C1 - 1-2-4	12
	C4 - 1-4	20
S42772001	C1 - 6	12
	Ga2 - 6	98
S42773001	C1 - 7	12
	Ga2 - 7	98
S42774101	C2 - 12	16
	C5 - 12	22
S42775001	C3 - 130	18
S42776001	C3 - 133	18
S42777001	C1 - 140	14
	Ga2- 140-1	98
S42778000	C2 - 12-4	16
	C5 - 12-4	22
S42779001	C2 - 12-5	16
	C5 - 12-5	22
S42780000	C2 - 16	16
S42781001	C2 - 17	16
S42782201	C2 - 35	16
	C5 - 35	22
S42783000	C2 - 36	16

CODE	REF.NO.	Page
S42783000	C5 - 36	22
S42784001	C2 - 38	16
	C5 - 38	22
S42785001	C2 - 55	16
	C5 - 55	22
S42787001	C1 - 75-1	14
	C4 - 75-1	20
	Ga2- 75-1	98
	Ga4- 75-1	102
S42788000	C3 - 87	18
S42789001	C3 - 90	18
	C6 - 90	24
S42790000	C3 - 101	18
S42791001	C3 - 103	18
S42792001	C3 - 105	18
S42793000	C3 - 120	18
S42795101	C3 - 125	18
	C6 - 125	24
S42796001	C3 - 127	18
	C6 - 127	24
S42797001	C1 - 140	14
	Ga2- 140-2	98
S42798001	C1 - 75-3	14
	C4 - 75-3	20
	Ga2- 75-3	98
	Ga4- 75-3	102
S42799001	C1 - 75-4	14
	C4 - 75-4	20
	Ga2- 75-4	98
	Ga4- 75-4	102
S42800001	C1 - 75-5	14
	C4 - 75-5	20
	Ga2- 75-5	98
	Ga4- 75-5	102
S42801001	C1 - 73	14
	C4 - 73	20
	Ga2- 73	98
	Ga4- 73	102
S42802001	C1 - 75-6	14
	C4 - 75-6	20
	Ga2- 75-6	98
	Ga4- 75-6	102
S42803001	V - 1	80
	C7 - 141	26
S42806001	V - 1	80
	C7 - 141	26
S42808001	V - 1	80
	C7 - 141	26
S42810001	V - 1	80
	C7 - 141	26
S42812001	V - 1	80
	C7 - 141	26
S42814009	Z - 1	92
S42815009	Z - 1-1	92
S42816001	C5 - 12-1	22
S42816101	C2 - 12-1	16
S42817001	C3 - 79	18
S42818101	E - 14-1	38
S42827000	F - 23	42
S42830001	B - 1	8
S42831001	D1 - 3	34
S42832001	D1 - 5	34
S42833201	D1 - 21	34

CODE	REF.NO.	Page
S42834001	D1 - 26	34
S42835001	D1 - 27	34
S42836001	D2 - 39	36
S42837001	D2 - 39-1	36
S42838001	T1 - 1	70
S42839101	D2 - 48	36
S42840101	D2 - 51	36
S42842001	T1 - 2	70
S42843001	D2 - 64-1	36
	Ga1 - A	96
S42844001	D2 - 64-2	36
	Ga1 - B	96
S42845001	D2 - 64-3	36
	Ga1 - C	96
S42846001	D2 - 64-4	36
	Ga1 - D	96
S42847001	D2 - 64-5	36
	Ga1 - E	96
S42848001	D2 - 64-8	36
	Ga1 - J	96
S42849001	D2 - 64-9	36
	Ga1 - XY	96
S42850409	U1 - 1	74
S42851301	U1 - 1-1	74
S42852309	U1 - 1	74
S42853201	U1 - 1-1	74
S42856001	J - 40	48
S42858001	K - 12	52
S42859001	K - 27	52
S42864101	K - 28	52
S42867001	T1 - 1-2	70
	T1 - 2-6	70
	T2 - 3-2	72
S42868001	L - 8	54
S42870101	L - 11	54
S42871101	L - 12	54
S42873101	L - 14	54
S42874001	L - 17	54
S42875000	A1 - 16	2
S42876000	A1 - 17	2
S42877001	A1 - 18	2
S42878000	C1 - 1-2-13	12
	C4 - 1-13	20
S42880001	D2 - 70	36
S42882001	Z - 58	93
S42883001	Z - 90	94
S42884001	C1 - 75-2	14
	C4 - 75-2	20
	Ga2- 75-2	98
	Ga4- 75-2	102
S42885001	D1 - 8	34
S42886001	J - 25	48
S42887001	J - 25-1	48
S42888001	C9 - 138	30
	Ga3- 138	100
S42890001	Z - 92	94
S43169009	M - 1	56
S43170009	M - 1-1	56
S43171009	M - 1-2	56
S43172009	M - 1-3	56
S43173001	M - 1-29	56
S43183100	M - 1-11	56
S43186000	M - 1-17	56

From the library of: Diamond Needle Corp

CODE	REF.NO.	Page
S43188000	M - 2-6	57
S43190000	M - 10	57
S43191000	M - 11	57
S43192000	P - 1	64
S43194000	P - 2	64
S43196000	P - 3	64
S43197000	P - 4	64
S43198101	P - 22	64
S43201000	M - 3-4	57
S43202000	P - 21	64
S43203000	P - 35-1	64
	AA2- 3-1-10	88
S43204000	P - 35-2	64
S43206000	P - 20	64
S43210001	R - 1	66
S43220209	S - 1	68
S43223009	S - 1-1	68
S43224000	S - 1-9	68
S43225000	S - 1-10	68
S43226000	S - 1-3	68
S43227200	S - 1-4	68
S43228000	S - 1-13	68
S43229001	S - 1-2	68
S43236009	S - 2	68
S43237000	S - 1-7	68
S43240009	M - H-9	58
S43241009	M - H-1	58
S43242009	M - H-2	58
S43244009	M - H-6	58
S43245009	M - H-4	58
S43246009	M - H-5	58
S43247009	M - H-7	58
S43248009	M - H-8	58
S43249001	W - 1	80
S43250000	W - 1-1	80
S43251000	W - 1-2	80
S43252000	W - 1-3	80
S43253000	W - 1-4	80
S43254000	W - 1-5	80
S43255000	W - 1-7	80
S43256000	W - 1-8	80
S43257000	W - 1-9	80
S43259001	W - 1-18	80
S43267000	W - 1-14	80
S43268000	W - 1-15	80
S43269000	W - 1-19	80
S43270000	W - 1-16	80
S43271000	W - 1-11	80
S43272000	W - 1-12	80
S43273000	Z - 71	94
S43274000	M - 1-16	56
S43275000	M - 1-20	56
S43276000	M - 1-21	56
S43277000	M - 1-22	56
S43278000	M - 31	57
S43279100	AA1- 2-1-1	86
S43309000	M - 1-24	56
S43369000	M - 3-2	57
S43370000	M - 3-3	57
S43671109	U1 - 1-2	74
S43672109	U1 - 1-2-3	74
S43673000	F - 35	42
S43674000	S - 3	68

CODE	REF.NO.	Page
S43675000	S - 4	68
S43676001	Z - 74-1	94
S43677001	C1 - 91	14
	C4 - 91	20
S43678009	N - 1-1	60
S43679001	N - 1-1-5	60
	N - 1-2-5	60
S43680001	N - 1-1-5-1	60
	N - 1-2-5-1	60
S43682000	N - 1-1-5-2	60
	N - 1-2-5-2	60
S43683001	N - 1-1-5-1-2	60
	N - 1-2-5-1-2	60
	N - 27	62
	Y - 1-11-6	84
	AA1- 6-1	86
	AA2- 3-2-1	88
	AA2- 4-3-1	88
	AA3- 2-2-1	90
S43684001	N - 1-1-5-1-1	60
	N - 1-2-5-1-1	60
S43686000	N - 1-1-11	60
S43687001	N - 8-1	60
S43687002	N - 8-2	60
S43688001	N - 9-1	60
S43688002	N - 9-2	60
S43689001	B - 14-1-5	8
	B - 14-2-5	8
S43691001	Ga3 - 89	100
S43691002	Ga3 - 89	100
S43691003	Ga3 - 89	100
S43693000	D2 - 40	36
S43694009	N - 1-2	60
S43696000	N - 28	62
	Y - 1-11-7	84
	AA1- 6-2	86
	AA2- 4-3-2	88
	AA3- 2-2-2	90
S43697001	C9 - 150-1	30
	Ga3- 150-1	100
S43698001	C9 - 150-2	30
	Ga3- 150-2	100
S43699001	C9 - 150-3	30
	Ga3- 150-3	100
S43700001	C8 - 151-1	28
	Ga2- 151-1	98
S43821001	C8 - 151-2	28
	Ga2- 151-2	98
S43822001	C8 - 151-3	28
	Ga2- 151-3	98
S43823001	C9 - 152	30
	Ga3- 152	100
S43824001	C9 - 153-1	30
	Ga3- 153-1	100
S43825001	C9 - 153-2	30
	Ga3- 153-2	100
S43826001	C9 - 153-3	30
	Ga3- 153-3	100
S43827001	C9 - 153-4	30
	Ga3- 153-4	100
S43828001	C9 - 153-5	30
	Ga3- 153-5	100
S43829001	C9 - 153-6	30

CODE	REF.NO.	Page
S43829001	Ga3- 153-6	100
S43830001	C9 - 153-7	30
	Ga3- 153-7	100
S43831100	C2 - 93	16
	C5 - 93	22
S43832001	Z - 74	94
S43833109	AA1- 1	86
S43834109	AA1- 1-1	86
S43835100	AA1- 1-1-11	86
S43836201	AA1- 2	86
S43837001	AA3- 2	90
S43838001	AA3- 2-1	90
S43839005	AA3- 2-2	90
S43839008	AA2- 4-3	88
S43841009	AA2- 3	88
S43842009	AA2- 3-1	88
S43843009	AA2- 3-1-11-1	88
S43844001	AA2- 3-2	88
S43846009	AA2- 4	88
S43847101	AA1- 6	86
S43977101	AA1- 2-1	86
S43979001	AA2- 5	88
S43980001	AA2- 5-1	88
S43981000	W - 1-17	80
S43982001	B - 14-1-1	8
	B - 14-2-1	8
S43984001	B - 14-1	8
S43985001	B - 14-2	8
S43986001	C1 - 202	14
	Ga3- 202	100
S43987001	C1 - 203	14
	Ga3- 203	100
S44387009	A2 - 15	6
S44456000	C6 - 101	24
S44457000	C6 - 102	24
S44458001	C6 - 103	24
S44459001	C6 - 105	24
S44483001	A1 - 22-1	2
	A2 - 22-1	4
S44484001	A2 - 22-1-1	4
S44485001	A1 - 22-2	2
	A2 - 22-2	4
S44487001	A1 - 22-6	2
	A2 - 22-6	4
S44494001	A1 - 22	2
	A2 - 22	4
S44604000	A2 - 16	4
S44605009	A2 - 103	4
S44606001	A2 - 105	4
S44607001	A2 - 121	6
S44608001	C10- 138	32
	Ga5- 138	104
S44610001	A2 - 111	4
S44611001	A2 - 113	4
S44612001	A2 - 29	4
S44613001	C4 - 7	20
	Ga4- 7	102
S44614001	C4 - 6	20
	Ga4- 6	102
S44615000	C5 - 16	22
S44616001	C5 - 17	22
S44617001	C6 - 70	24
S44618001	C6 - 67	24

CODE	REF.NO.	Page
S44619001	C6 - 130	24
S44620001	C6 - 133	24
S44621001	C4 - 140	20
	Ga4- 140-1	102
S44622001	C4 - 140	20
	Ga4- 140-2	102
S44623000	C6 - 87	24
S44624000	C6 - 120	24
S44626009	A2 - 101	4
S44628009	A2 - 13	4
S44629000	A1 - 920	2
	A2 - 920	6
S44663000	P - 6	64
S44665000	P - 6-1	64
S44665002	P - 6-2	64
S44745009	Y - 1-11	84
S44746000	N - 28-1	62
	Y - 1-11-7-1	84
	AA1- 6-2-1	86
	AA2- 4-3-2-1	88
	AA3- 2-2-2-1	90
S44748001	Y - 1-11-2	84
	AA2- 3-2-2	88
	AA2- 4-3-3	88
	AA3- 2-2-3	90
S44749001	AA1- 6-3	86
S44750000	N - 28-2	62
	Y - 1-11-7-2	84
	AA1- 6-2-2	86
	AA2- 3-2-6	88
	AA2- 4-3-2-2	88
	AA3- 2-2-2-2	90
S44757001	C6 - 68	24
S44759000	AA2- 3-2-4	88
S44760000	AA2- 3-2-5	88
S44793009	Y - 1	84
S44794001	X - 3	82
S44795001	AB - 1	90
S44805001	T2 - 3	72
S44806000	T2 - 3-5	72
S44807000	T2 - 3-5-1	72
S44924001	C3 - 126	18
	C6 - 126	24
S45147001	B - 2	8
S45199000	S - 20	68
S45591001	Ga5- 89	104
S45593001	Ga5- 89	104
S45595001	Ga5- 89	104
S45597001	C10- 150-1	32
	Ga5- 150-1	104
S45598001	C10- 150-2	32
	Ga5- 150-2	104
S45599001	C10- 150-3	32
	Ga5- 150-3	104
S45600001	C10- 151-1	32
	Ga5- 151-1	104
S45601001	C10- 151-2	32
	Ga5- 151-2	104
S45602001	C10- 151-3	32
	Ga5- 151-3	104
S45603001	C10- 152	32
	Ga5- 152	104
S45604001	C10- 153-1	32

CODE	REF.NO.	Page
S45604001	Ga5- 153-1	104
S45605001	C10- 153-2	32
	Ga5- 153-2	104
S45606001	C10- 153-3	32
	Ga5- 153-3	104
S45607001	C10- 153-4	32
	Ga5- 153-4	104
S45608001	C10- 153-1	32
	Ga5- 153-1	104
S45609001	C10- 153-2	32
	Ga5- 153-2	104
S45610001	C10- 153-3	32
	Ga5- 153-3	104
S45611001	C10- 153-4	32
	Ga5- 153-4	104
S45612001	C10- 153-1	32
	Ga5- 153-1	104
S45613001	C10- 153-2	32
	Ga5- 153-2	104
S45614001	C10- 153-3	32
	Ga5- 153-3	104
S45615001	C10- 153-4	32
	Ga5- 153-4	104
S45616001	C10- 153-3	32
	Ga5- 153-3	104
S45617001	C10- 153-4	32
	Ga5- 153-4	104
S45724009	Z - 19	92
S46405000	F - 24	42
S46460000	U1 - 1-15	74
	U2 - 26	78
S46476001	P - 7	64
S47224001	C1 - 204	14
S47592000	M - 2-4	56
S47594000	M - 2-7	57
U32744000	R - 1-5	66
U34870001	S - 1-2-3	68
U38337000	R - 1-1	66
U38338000	R - 1-2	66
0A4300605	S - 1-6	68
	S - 1-11	68
0A4400605	M - 41	57
0A5400805	S - 1-5	68
0A5400806	M - 1-6	56
	P - 10	64
	P - 12	64
	P - 14	64
	P - 27	64
	P - 38	64
0A5401006	M - 1-7	56
0A5401605	M - 43	57
0A5403006	M - 1-5	56
0B1351606	Z - 88	94
	Z - 94	94
002300403	T1 - 1-11	70
	T1 - 2-15	70
	T2 - 3-11	72
002300603	S - 1-14	68
002301203	P - 8	64
004400603	T1 - 1-3	70
	T1 - 2-7	70
	T2 - 3-3	72
004400814	C2 - 13	16

CODE	REF.NO.	Page
004400814	C5 - 13	22
004501003	P - 25	64
008400604	K - 8-4	52
	M - 1-23	56
	S - 1-17	68
011679312	C1 - 1-1-24	12
	C1 - 1-2-20	12
	C4 - 1-20	20
014400522	C3 - 113	18
014679320	H - 1-7	46
014680422	J - 42	48
	C1 - 1-1-15-1	12
	C1 - 1-2-6-1	12
	C2 - 27	16
	C4 - 1-6-1	20
	C5 - 27	22
014680622	E - 3	38
	G - 28	44
	H - 1-9	46
	J - 7-2	48
	L - 24	54
	C2 - 18	16
	D1 - 9	34
	D1 - 19	34
014710522	K - 31	52
	C6 - 113	24
014760622	B - 9	8
	E - 7	38
	E - 10	38
	E - 15	38
	J - 33	48
	Z - 10	92
	Z - 87	94
	C1 - 1-1-18	12
	C1 - 1-2-9	12
	C2 - 37	16
	C2 - 39	16
	C2 - 56	16
	C4 - 1-9	20
	C5 - 18	22
	C5 - 37	22
	C5 - 39	22
	C5 - 56	22
	D2 - 39-2	36
014770622	B - 12	8
	B - 12	8
	E - 13-1	38
	J - 2	48
	J - 22	48
	C2 - 42	16
	C2 - 51	16
	C3 - 100	18
	C3 - 104	18
	C3 - 107	18
	C5 - 42	22
	C5 - 51	22
	C6 - 100	24
	C6 - 104	24
	C6 - 107	24
014780622	B - 4	8
	B - 15	8
017081606	N - 32	62
	U1 - 1-2-1-3	74

From the library of: Diamond Needle Corp

CODE	REF.NO.	Page
017081606	U1 - 1-2-2-3	74
	U1 - 1-2-4	74
	U1 - 1-2-9	74
017082203	N - 19	62
017082206	U1 - 9	76
	U2 - 9	78
017501216	Y - 1-1-23	84
017751412	D2 - 47	36
017821813	AA3 - 2-3	90
017822212	L - 25	54
018060822	L - 19	54
018061036	M - 4	57
018061222	D1 - 35	34
018061422	L - 2	54
018081222	Z - 74-2	94
018081636	S - 7	68
018082022	A2 - 102	4
	A2 - 104	4
018300836	Y - 1-1-21	84
	Y - 1-1-22	84
018301036	Y - 1-1-8	84
018301236	Y - 1-1-7	84
018302032	AA3- 2-1-2	90
018400622	C1 - 1-1-20	12
	C1 - 1-2-11	12
	C4 - 1-11	20
018400632	Z - 63	94
018400822	P - 5	64
018401222	P - 15	64
	P - 41	64
018401636	C3 - 88	18
	C6 - 88	24
018405032	Z - 59	93
018501022	C2 - 24	16
	C5 - 24	22
	D1 - 16	34
018501222	A2 - 107	4
	C1 - 1-2-22	12
	C3 - 81	18
	C4 - 1-22	20
018501422	E - 20	38
	L - 22	54
	C3 - 84	18
	C6 - 145	24
018501622	A2 - 106	4
	C2 - 30	16
	C3 - 118	18
	C5 - 30	22
	C6 - 118	24
	C6 - 119	24
	C6 - 143	24
018502522	C3 - 119	18
018503022	C2 - 63	16
	C5 - 63	22
018505022	C2 - 62	16
	C5 - 62	22
018680822	X - 3-5	82
	X - 4-2	82
	X - 5-2	82
	C2 - 12-3	16
	C2 - 34	16
	C2 - 86	16
	C3 - 123	18

CODE	REF.NO.	Page
018680822	C5 - 12-3	22
	C5 - 34	22
	C5 - 86	22
	C6 - 123	24
018681022	J - 11	48
	K - 6	52
018681232	Y - 1-1-5	84
021060106	Z - 55	93
	U1 - 1-24	76
	U2 - 36	78
021060206	P - 30	64
021080106	N - 23	62
021300106	Y - 1-15	84
021400102	Z - 60	93
021400106	M - 45	57
021500103	N - 5	60
021500106	S - 9	68
	Z - 34-8-3	93
	Z - 34-11-1	93
021500216	Y - 1-1-24	84
021660102	K - 36	52
	A1 - 22-4	2
	A1 - 50-5	2
	A2 - 22-4	4
021660306	C8 - 158	28
	Ga2- 158	98
021670202	K - 34	52
021680202	H - 1-24	46
021750102	D2 - 45	36
022120306	U1 - 1-2-1-7	74
	U1 - 1-2-2-7	74
025030135	AA1- 1-1-9	86
025030232	N - 1-1-8	60
	N - 1-2-8	60
	Y - 1-11-5	84
	A1 - 22-5	2
	A2 - 22-5	4
	AA1- 2-1-3	86
025030236	T1 - 1-13	70
	T1 - 2-17	70
	T2 - 3-13	72
025040232	P - 16	64
	P - 42	64
	C1 - 1-1-19	12
	C1 - 1-2-10	12
	C3 - 129	18
	C4 - 1-10	20
	C6 - 129	24
	U1 - 42	76
	U2 - 42	78
025040236	M - 44	57
025050232	C2 - 25	16
	C2 - 60	16
	C3 - 83	18
	C3 - 117	18
	C5 - 25	22
	C5 - 60	22
	C6 - 117	24
	C6 - 144	24
025050236	S - 6	68
	U1 - 1-5	74
025060132	C2 - 15	16
	C5 - 15	22

CODE	REF.NO.	Page
025060232	D1 - 37	34
025060236	M - 6	57
	T1 - 2-4	70
025060336	Z - 56	93
	U1 - 1-22	76
	U2 - 34	78
025080232	N - 21	62
	Z - 74-3	94
025080236	U1 - 1-2-6	74
	U1 - 12	76
	U2 - 12	78
025080336	N - 22	62
025350132	Y - 1-1-15	84
025350332	Y - 1-7	84
	A1 - 32	2
	A2 - 32	4
025660132	A1 - 50-4	2
025680132	Q - 7	66
025680232	F - 8	42
	H - 1-27	46
	H - 4	46
	J - 12	48
	J - 39	48
	C1 - 8	12
	C4 - 8	20
	Ga2 - 8	98
	Ga4 - 8	102
025710232	C9 - 19	30
025750132	K - 16	52
026120236	U1 - 1-2-1-9	74
	U1 - 1-2-2-9	74
028030242	N - 1-1-7	60
	N - 1-2-7	60
	Y - 1-1-4	84
028030246	T1 - 1-12	70
	T1 - 2-16	70
	T2 - 3-12	72
028040242	P - 17	64
	P - 43	64
028040246	C3 - 89	18
	C6 - 89	24
028050242	C2 - 61	16
	C3 - 82	18
	C5 - 61	22
028050246	Z - 34-8-2	93
	U1 - 1-6	74
028060242	L - 3	54
	D1 - 36	34
028060246	M - 5	57
	P - 31	64
	U1 - 1-23	76
	U2 - 35	78
028080240	U1 - 11	76
	U2 - 11	78
028080242	N - 20	62
	Z - 74-4	94
028080246	N - 33	62
	U1 - 1-2-1-4	74
	U1 - 1-2-2-4	74
	U1 - 1-2-5	74
	U1 - 1-2-10	74
028120246	U1 - 1-2-1-10	74
	U1 - 1-2-2-10	74

CODE	REF.NO.	Page
028350242	J - 21-6	48
	Y - 1-8	84
	AA1- 2-1-8	86
028680242	F - 9	42
032361306	U1 - 1-14	74
032422003	Z - 93	94
	U1 - 38	76
	U2 - 38	78
032461606	Z - 57	93
037200615	W - 1-10	80
037300615	W - 1-13	80
037300816	S - 1-12	68
037301015	W - 1-6	80
037301215	Z - 4-3	92
037521016	U1 - 1-4	74
039411215	U1 - 1-10	74
048020342	AA1- 1-1-10	86
048030342	K - 15	52
	C1 - 1-1-4	12
048040342	K - 20	52
	L - 16	54
	C1 - 1-1-10	12
	C1 - 1-2-16	12
	C4 - 1-16	20
	D2 - 63	36
048050342	H - 1-10	46
	C1 - 1-1-17	12
	C1 - 1-2-8	12
	C4 - 1-8	20
048050346	T1 - 1-15	70
	T1 - 2-19	70
	T2 - 3-15	72
048050142	T1 - 2-3	70
048060342	J - 32	48
	C2 - 44	16
	C2 - 54	16
	C3 - 109	18
	C3 - 116	18
	C5 - 44	22
	C5 - 54	22
	C6 - 109	24
	C6 - 116	24
048070342	J - 19	48
048080342	E - 18	38
048100142	H - 1-4	46
048150142	B - 7	8
048160242	C2 - 52	16
	C3 - 114	18
	C5 - 52	22
	C6 - 114	24
	C6 - 142	24
048200142	D1 - 18	34
048320242	Z - 74-1-1	94
052400606	T1 - 1-16	70
	T1 - 2-20	70
	T2 - 3-16	72
052501205	N - 2	60
060670512	F - 16	42
060670612	G - 6	44
	AA1- 2-1-9	86
	AA1- 2-3	86
060680512	K - 19	52
060680712	J - 4	48

CODE	REF.NO.	Page
060680712	D1 - 22	34
061660806	A1 - 22-3	2
	A2 - 22-3	4
062300612	P - 28	64
	P - 29	64
	AA1- 2-1-2	86
	AA1- 2-1-6	86
	AA2- 3-1-12	88
062301205	T1 - 1-6	70
	T1 - 2-10	70
	T2 - 3-6	72
062301616	AA1- 1-1-13	86
062302505	Y - 1-11-3	84
062302506	N - 1-1-6	60
	N - 1-2-6	60
062400512	A1 - 39	2
	A2 - 39	4
062400806	Q - 2	66
062400812	A2 - 112	4
	C3 - 128	18
	C6 - 128	24
062401006	Z - 3	92
062404005	Y - 1-11-11	84
062501406	Z - 34-11-4	93
062660412	E - 14-1-3	38
	E - 14-2-3	40
062660712	E - 14-1-7	38
	E - 14-2-7	40
	A1 - 50-3	2
062670412	G - 31	44
062670512	F - 27	42
	F - 39	42
	F - 49	42
	Y - 1-6	84
	A1 - 22-7	2
	A2 - 22-7	4
	C1 - 75-7	14
	C4 - 75-7	20
	C9 - 198	30
	Ga2- 75-7	98
	Ga4- 75-7	102
062670612	G - 4	44
	G - 24	44
	L - 10	54
	L - 32	54
	Z - 91	94
	A1 - 23	2
	A2 - 23	4
	AA2- 3-1-5	88
062670712	C1 - 76	14
	C4 - 76	20
062670812	AA2- 4-5	88
062671212	C1 - 77	14
	C4 - 77	20
062680512	H - 1-18	46
	K - 9	52
	K - 22	52
	C1 - 11	14
	C4 - 11	20
	AA2- 3-1-9	88
062680612	F - 7	42
	F - 30	42
	A1 - 28	2

CODE	REF.NO.	Page
062680612	A2 - 28	4
062680712	B - 14-1-7	8
	B - 14-2-7	8
062680812	H - 3	46
	C3 - 66	18
	C6 - 66	24
	C6 - 69	24
062681212	H - 2	46
	D1 - 30	34
	D2 - 60	36
062681412	Q - 6	66
062710612	G - 2	44
062711012	A1 - 21	2
	A2 - 21	4
062711212	A1 - 14	2
	A2 - 14	4
	C2 - 64	16
	C5 - 64	22
062760812	L - 28	54
062761012	A2 - 122	6
	C3 - 71	18
	C6 - 71	24
062761412	C2 - 14	16
	C5 - 14	22
062771012	L - 20	54
070688850	C2 - 43	16
	C3 - 108	18
	C5 - 43	22
072630260	B - 6	8
081003670	E - 12	38
	E - 17	38
100022004	H - 1-26	46
100022005	J - 24	48
100032004	J - 51	50
100090004	E - 2	38
100136001	G - 20	44
	H - 1-20	46
100242003	B - 18	8
	Y - 1-1-16	84
100250001	B - 11	8
	B - 11	8
100281001	D1 - 10	34
100360003	J - 54	50
100398001	G - 12	44
100402004	G - 17	44
100645003	K - 7	52
100659001	K - 35	52
100887001	Z - 30	92
101073001	U1 - 1-12	74
101121000	U1 - 1-13	74
101572101	Z - 28	92
101706001	B - 13-1	8
	E - 6-1	38
102630001	B - 16	8
102707002	C9 - 199	30
103950003	G - 18	44
104450109	Z - 1-2	92
	A1 - 4	2
	A1 - 10	2
	A1 - 43	2
	A2 - 4	4
	A2 - 10	4
	A2 - 43	4

From the library of: Diamond Needle Corp

CODE	REF.NO.	Page
104450109	D1 - 68	34
104525001	G - 14	44
	AA3- 2-6	90
104567001	F - 21	42
104821009	A1 - 5	2
	A2 - 5	4
105073001	U1 - 1-17	74
	U2 - 28	78
106129002	J - 21-5	48
106147002	J - 14	48
	L - 26	54
106588003	J - 25-3	48
106629002	J - 52	50
	A1 - 19	2
	A1 - 30	2
	A2 - 19	4
	A2 - 30	4
	A2 - 114	4
	A2 - 116	6
	C2 - 92	16
	C3 - 132	18
	C3 - 135	18
	C5 - 92	22
	D1 - 72	34
107017001	S - 1-20	68
107017002	A1 - 36	2
	A2 - 36	4
107038003	C1 - 78	14
	C4 - 78	20
107149001	F - 5	42
	F - 13	42
	F - 37	42
107272002	C6 - 132	24
	C6 - 135	24
107321003	A1 - 35	2
	A2 - 35	4
107321009	S - 1-19	68
107415009	B - 24	10
107415011	B - 24	10
107415014	B - 24	10
107415016	B - 24	8
107415018	B - 24	10
107415019	B - 24	10
107415021	B - 24	10
107415023	B - 24	10
107415416	Z - 17	92
107453001	D2 - 44	36
107606001	G - 14	44
107779001	Z - 29	92
107780001	Z - 31	93
108802001	F - 46	42
109239002	A1 - 26	2
	A2 - 26	4
109714000	Z - 5	92
	Z - 12	92
	Z - 21	92
109763002	L - 13	54
109893002	J - 27	48
	L - 4	54
110161004	J - 28	48
	J - 37	48
110168001	C1 - 1-2-18	12
	C4 - 1-18	20

CODE	REF.NO.	Page
110233001	J - 26	48
	J - 36	48
110367001	J - 31	48
110735001	K - 14	52
111140002	J - 50	50
111466101	D2 - 53	36
112738000	F - 36	42
113006001	F - 51	42
113316001	G - 5	44
114294001	G - 9	44
114483002	Z - 22	92
114486002	Z - 6	92
115186001	G - 19	44
115188001	G - 21	44
115559002	D1 - 31	34
	U1 - 3	76
	U2 - 3	78
116662003	U1 - 39	76
	U2 - 39	78
116694001	U1 - 10	76
	U2 - 10	78
117150001	F - 48	42
117291002	Y - 1-3	84
117363001	C9 - 193	30
117934009	A1 - 6	2
	A1 - 11	2
	A1 - 20-3	2
	A2 - 6	4
	A2 - 11	4
	A2 - 20-3	4
117936001	T1 - 1-17	70
	T1 - 2-21	70
	T2 - 3-17	72
117936009	A1 - 42	2
	A2 - 42	4
118064001	Z - 33	93
118837001	Z - 27	92
119255000	A2 - 22-1-3	4
119702004	U1 - 1-11	74
119707003	U1 - 7	76
	U2 - 7	78
119708001	U1 - 8	76
	U2 - 8	78
120438001	E - 23	38
120448001	H - 1-13	46
120990001	H - 1-14	46
122991001	Z - 14	92
123006001	B - 13-2	8
126863001	Z - 34-3	93
129986001	A1 - 37	2
	A2 - 37	4
132051001	B - 14-1-4	8
	B - 14-2-4	8
133172003	U1 - 1-3	74
133188001	U1 - 6	76
	U2 - 6	78
133740006	Z - 54	93
	U1 - 1-21	76
	U2 - 33	78
138444001	U1 - 41	76
	U2 - 41	78
140263000	D1 - 28	34
140392009	A1 - 7	2

CODE	REF.NO.	Page
140392009	A2 - 7	4
140647101	L - 31	54
140726000	B - 5	8
141492001	J - 25-2	48
141590001	H - 1-25	46
141786001	E - 1	38
141860001	Z - 74-1-2	94
142443001	Z - 26	92
142721001	Z - 32	93
142990001	Z - 34-10-3	93
143591001	C1 - 1-1-16	12
	C1 - 1-2-7	12
	C4 - 1-7	20
143882001	Z - 9	92
143910009	Z - 11	92
143966001	A1 - 50-2	2
144105000	H - 1-23	46
144110001	H - 1-21	46
144226001	Z - 50	93
144458001	B - 21	8
	K - 24	52
144504001	AA1 - 1-1-2	86
	AA3 - 2-1-11	90
144588001	G - 10	44
144712001	B - 2-1	8
145087001	Y - 1-1-12	84
145446001	G - 16	44
	G - 22	44
	H - 1-22	46
145472001	D2 - 54	36
145478101	J - 9	48
	L - 18	54
	L - 29	54
145480101	A1 - 25	2
	A2 - 25	4
145519001	G - 10	44
145547001	F - 26	42
145646011	B - 24	10
145646014	B - 24	10
145646016	B - 24	10
145646018	B - 24	10
145646019	B - 24	10
145646021	B - 24	8
145646024	B - 24	10
145646025	B - 24	10
145646421	Z - 17	92
145646425	Z - 17	92
146058001	AA1 - 1-1-4	86
	AA3 - 2-1-9	90
146059001	AA1 - 1-1-5	86
	AA3 - 2-1-8	90
146060000	AA1 - 1-1-6	86
	AA3 - 2-1-7	90
146080000	AA1 - 1-2	86
146206009	AA1 - 1-1-3	86
	AA3 - 2-1-10	90
146255000	Z - 52	93
	U1 - 1-20	76
	U2 - 32	78
146256001	Z - 51	93
	U1 - 1-19	76
	U2 - 31	78
146288001	K - 18	52

